

SERVICE MANUAL

Refrigerant
R410A

Indoor unit	Outdoor unit
ABYG30LRTE	AOYG30LETL
ABYG36LRTE	AOYG36LETL

ENINDEL CLIMA

CONTENTS

SPECIFICATIONS	1
DIMENSIONS	2
REFRIGERANT SYSTEM DIAGRAM	3
CIRCUIT DIAGRAM	4
INDOOR PCB CIRCUIT DIAGRAM	5
OUTDOOR PCB CIRCUIT DIAGRAM	9
ERROR DETECTION	14
PARTS (INDOOR UNIT)	16
PARTS (OUTDOOR UNIT)	21
ACCESSORIES	25

SPECIFICATIONS

ELECTRICAL DATA

TYPE		Cooling & Heating	
INDOOR UNIT		ABYG30LRTE	ABYG36LRTE
OUTDOOR UNIT		AOYG30LETL	AOYG36LETL
COOLING CAPACITY		8.50 kW	9.40 kW
HEATING CAPACITY		10.0 kW	11.2 kW
POWER SOURCE		230 V, 50 Hz	
RUNNING CURRENT	Cooling	11.6 A	12.8 A
	Heating	12.2 A	13.2 A
INPUT WATTS	Cooling	2.65 kW	2.93 kW
	Heating	2.77 kW	3.02 kW
E.E.R.	Cooling	3.21 kW/kW	3.21 kW/kW
C.O.P.	Heating	3.61 kW/kW	3.71 kW/kW
MOISTURE REMOVAL		2.5 L/hr	3.0 L/hr
AIRCIRCULATION INDOOR		1,660 m3/h	1,900 m3/h
AIRCIRCULATION OUTDOOR	Cooling	3,600 m3/h	3,800 m3/h
	Heating	3,600 m3/h	3,800 m3/h
MAXIMUM CURRENT	Cooling	17.0 A	18.5 A
	Heating	17.0 A	20.0 A

FAN MOTOR

INDOOR UNIT, Discrimination		MFH-45RV	
INDOOR UNIT	High	1,000 r.p.m.	1,000 r.p.m.
	Medium	910 r.p.m.	910 r.p.m.
	Low	750 r.p.m.	750 r.p.m.
	Quiet	650 r.p.m.	650 r.p.m.
OUTDOOR UNIT, Discrimination		MFE-60TVT	
OUTDOOR UNIT	Cooling	850 r.p.m.	900 r.p.m.
OUTDOOR UNIT	Heating	850 r.p.m.	900 r.p.m.

NOISE LEVEL

INDOOR UNIT	High	45 dB	47 dB
	Medium	43 dB	43 dB
	Low	37 dB	37 dB
	Quiet	32 dB	32 dB
OUTDOOR UNIT	Cooling	53 dB	54 dB
	Heating	55 dB	55 dB

COMPRESSOR AND REFRIGERANT

TYPE	Hermetic type, Inverter, 6 poles, DC motor, 2-cylinder rotary		
DISCRIMINATION	N-TF30ND1A		
WEIGHT (with oil)	15.3 kg		
REFRIGERANT TYPE	R410A		
PRECHARGED REFRIGERANT	2,100 g		
MAX PIPE HEIGHT	30 m		
FULL CHARGE	Pipe length	20 m	2,100 g
		30 m	2,500 g
		40 m	2,900 g
		50 m	3,300 g
ADDITIONAL CHARGE	40 g/m		

DIMENSIONS

INDOOR UNIT	H x W x D	240 x 1,660 x 700 mm
OUTDOOR UNIT	H x W x D	830 x 900 x 330 mm

WEIGHT

INDOOR UNIT	Shipping / Net	58 kg / 46 kg
OUTDOOR UNIT	Shipping / Net	68 kg / 61 kg

WWW.ENINDEL.COM

DIMENSIONS

(Unit : mm)

INDOOR UNIT

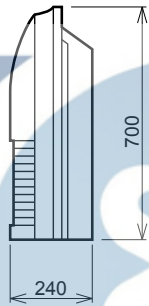
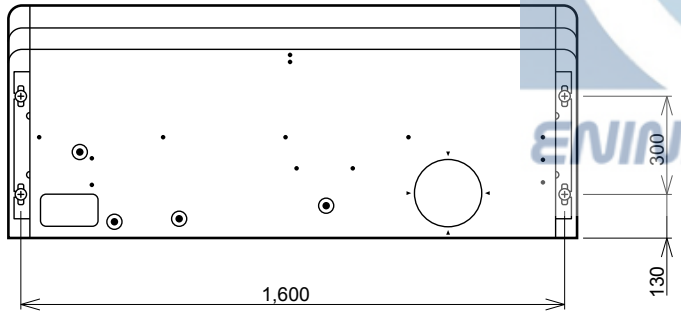
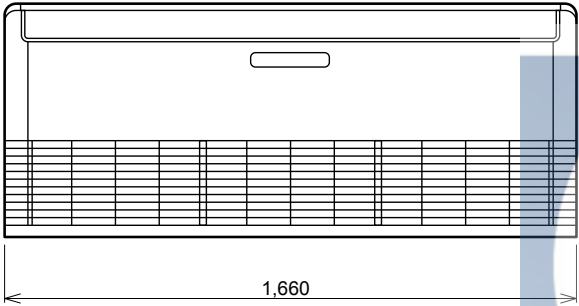

OUTDOOR UNIT

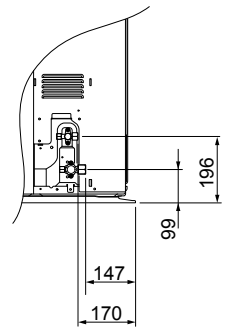
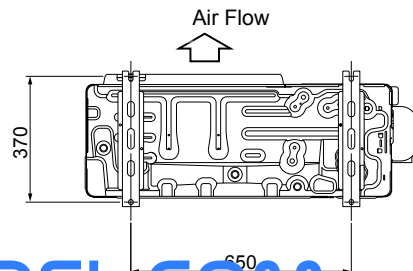
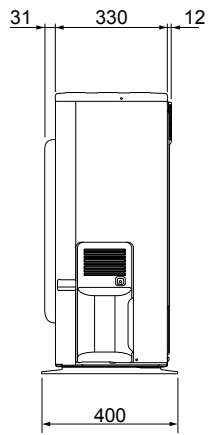
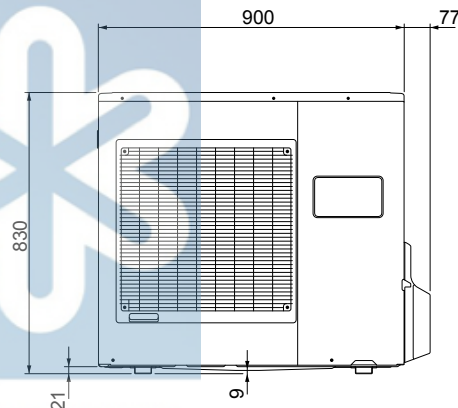
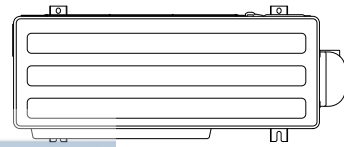

WWW.ENINDEL.COM

REFRIGERANT SYSTEM DIAGRAM

Refrigerant direction

→ : Cool

- - -> : Heat

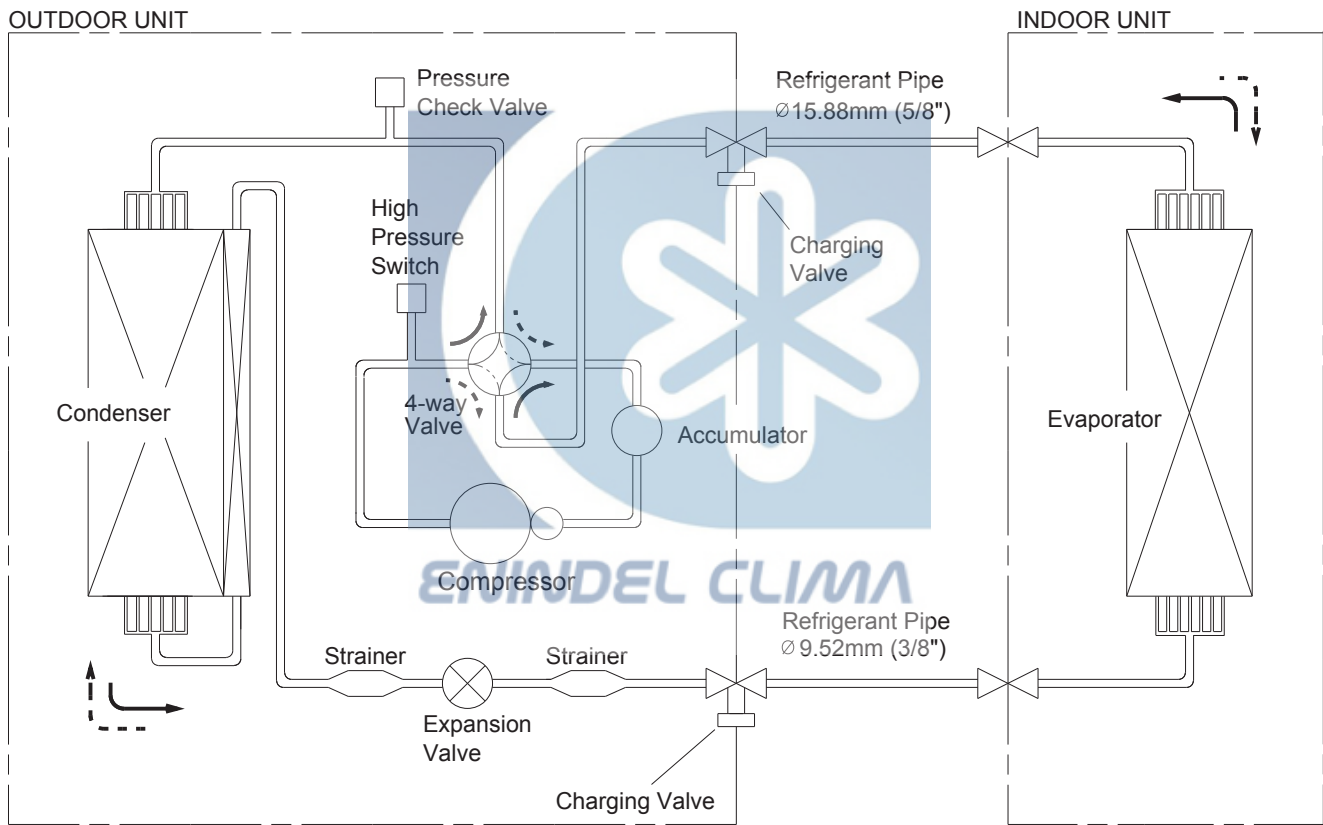

WWW.ENINDEL.COM

CIRCUIT DIAGRAM

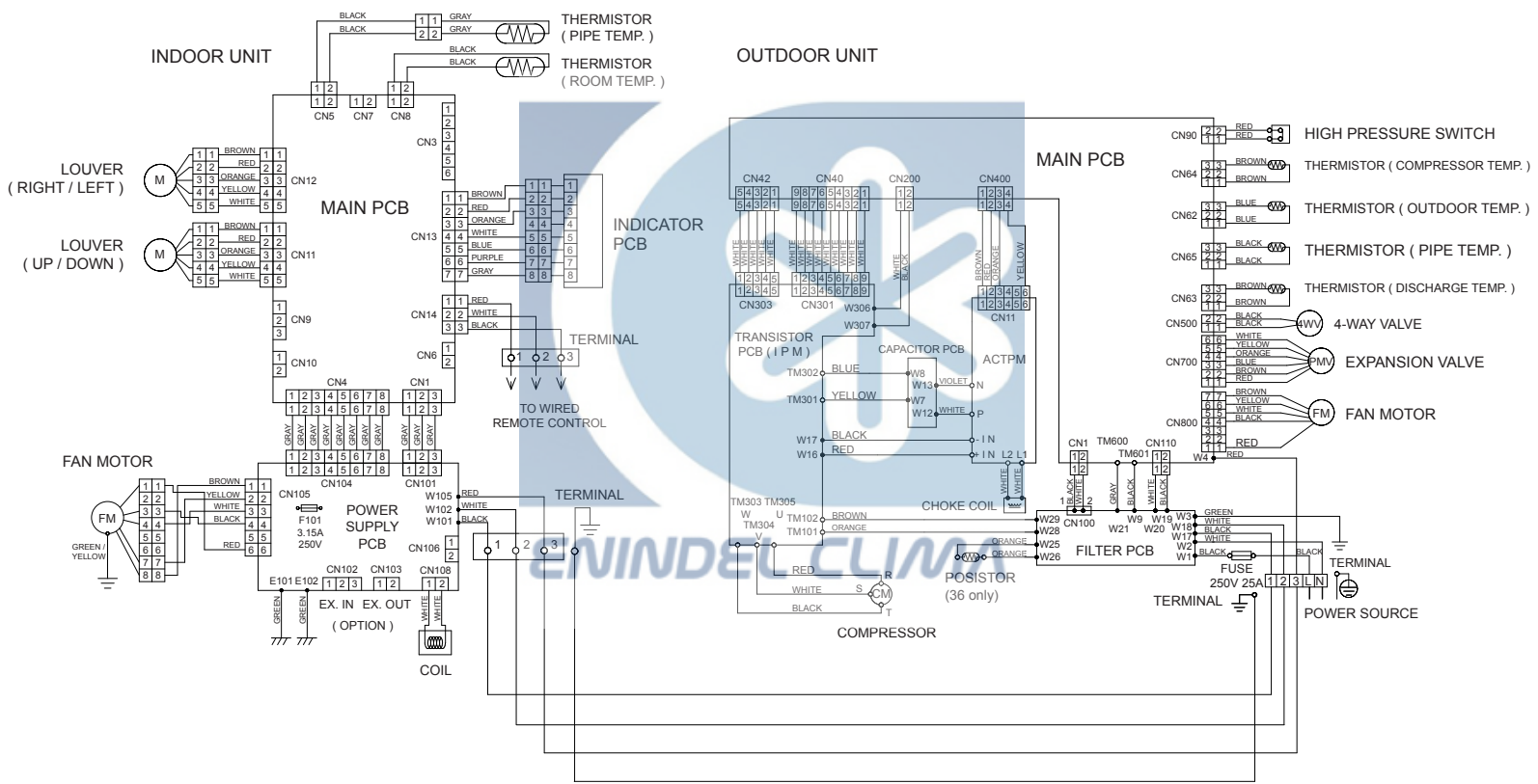

WWW.ENINDEL.COM

INDOR PCB CIRCUIT DIAGRAM

CONTROL UNIT
 ABYG30LRTE : EZ-0121SHSE
 ABYG36LRTE : EZ-0121THSE

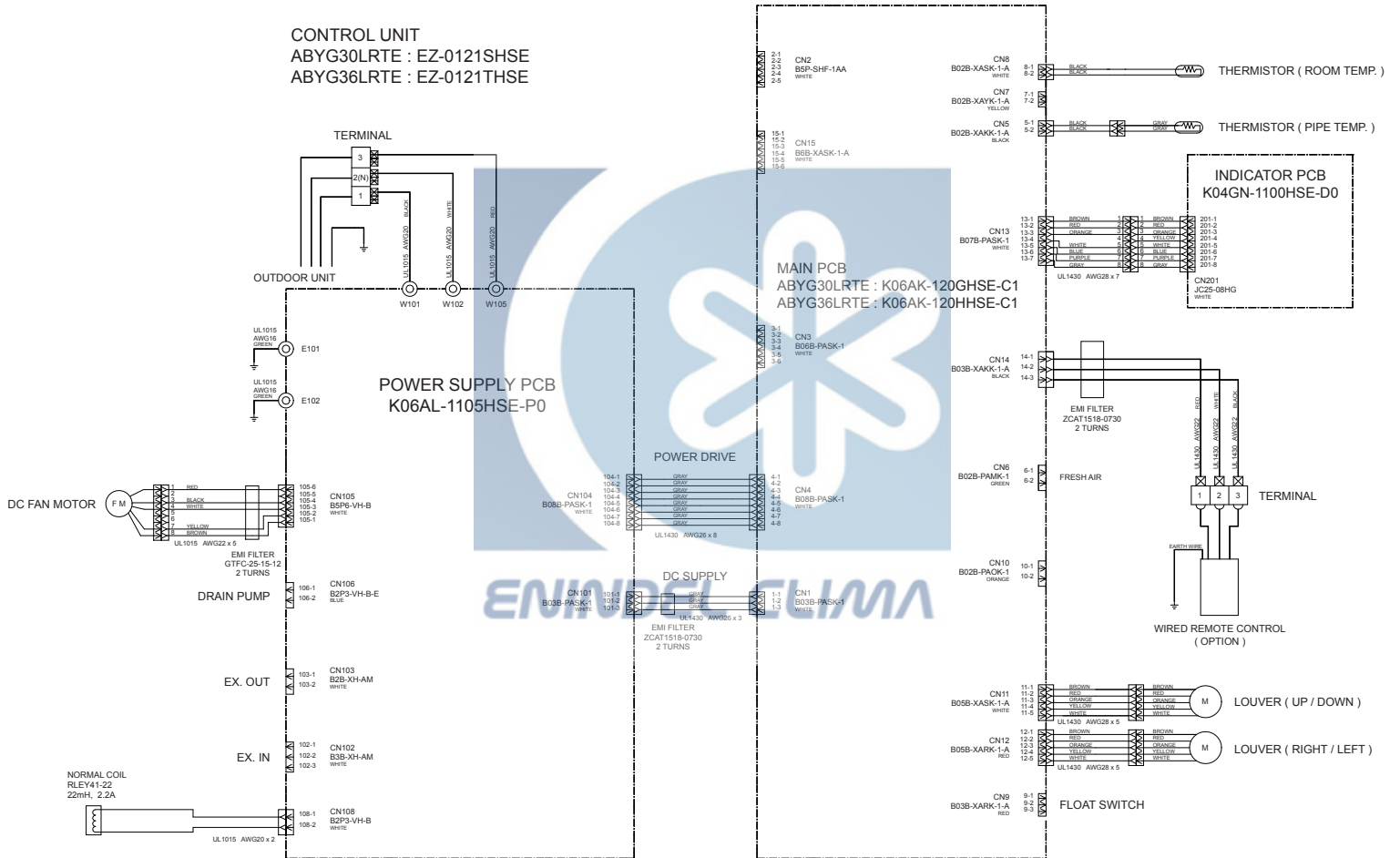

WWW.ENINDEL.COM

2013.01.18

INDOOR UNIT
 MAIN PCB
 ABYG30LRTE : K06AK-120GHSE-C1
 ABYG36LRTE : K06AK-120HHE-C1

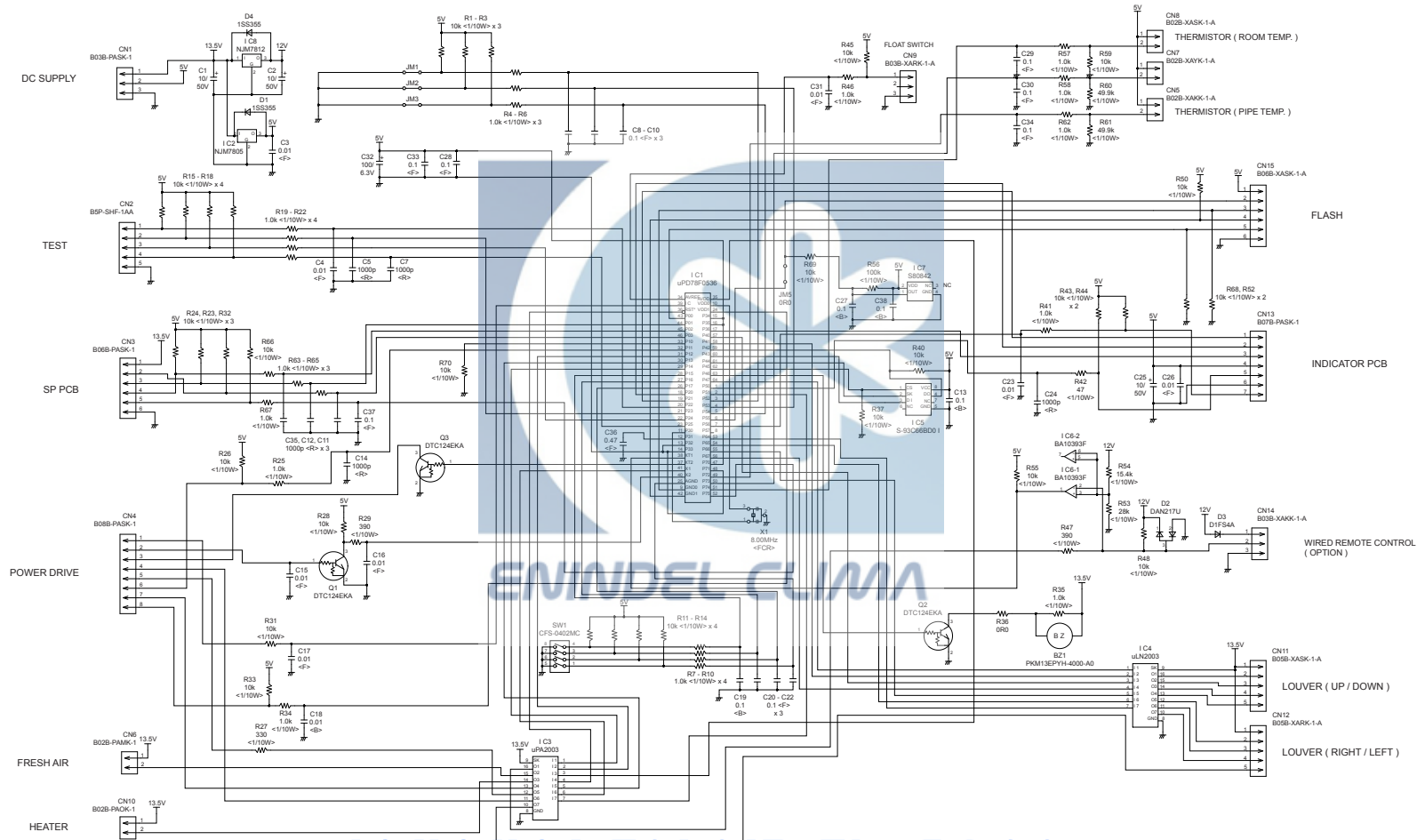

WWW.ENINDEL.COM

2013.01.18

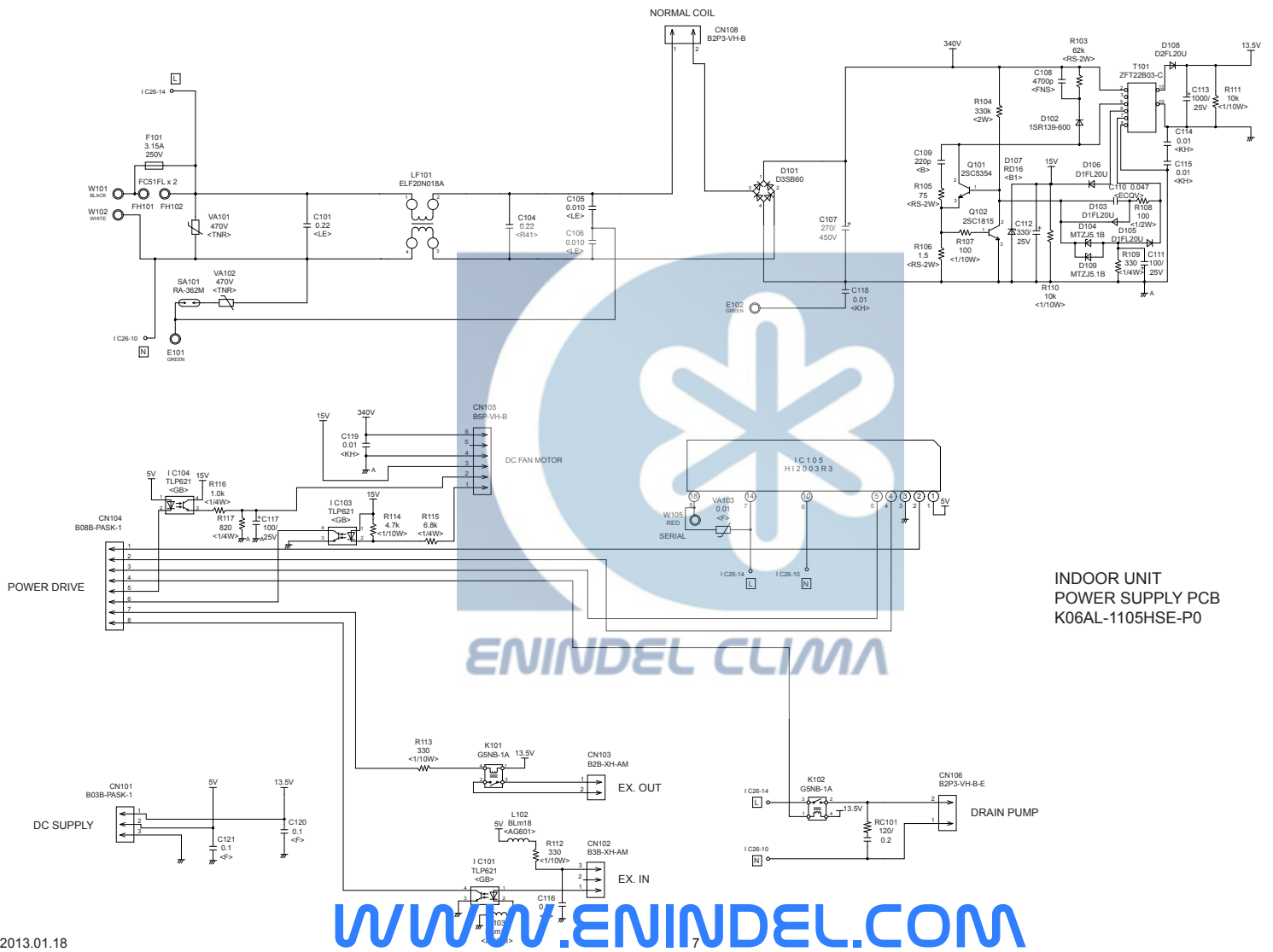

INDOOR UNIT
POWER SUPPLY PCB
K06AL-1105HSE-P0

2013.01.18

INDOOR UNIT
INDICATOR PCB
K04GN-1100HSE-D0

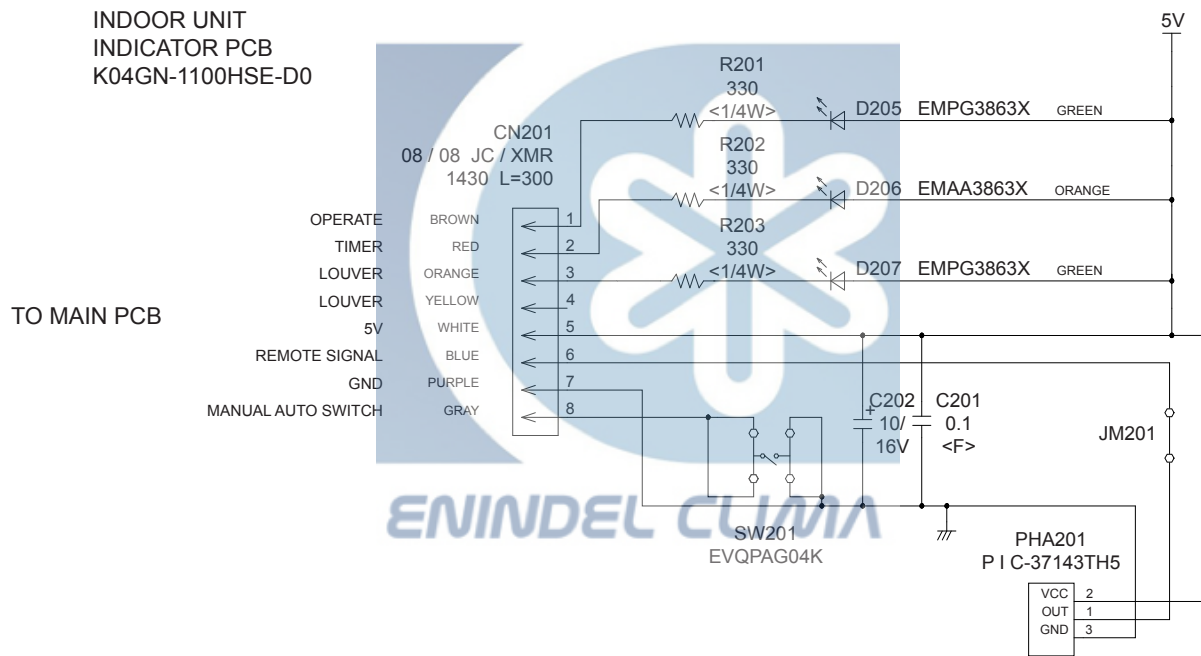

WWW.ENINDEL.COM

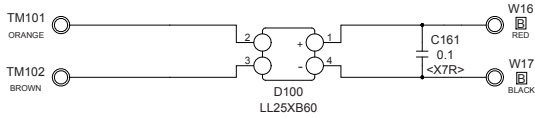

OUTDOOR UNIT
 TRANSISTOR PCB
 (I P M)
 AOYG30LETL : K07BT-0901HUE-TR0
 AOYG36LETL : K07BT-0900HUE-TR0

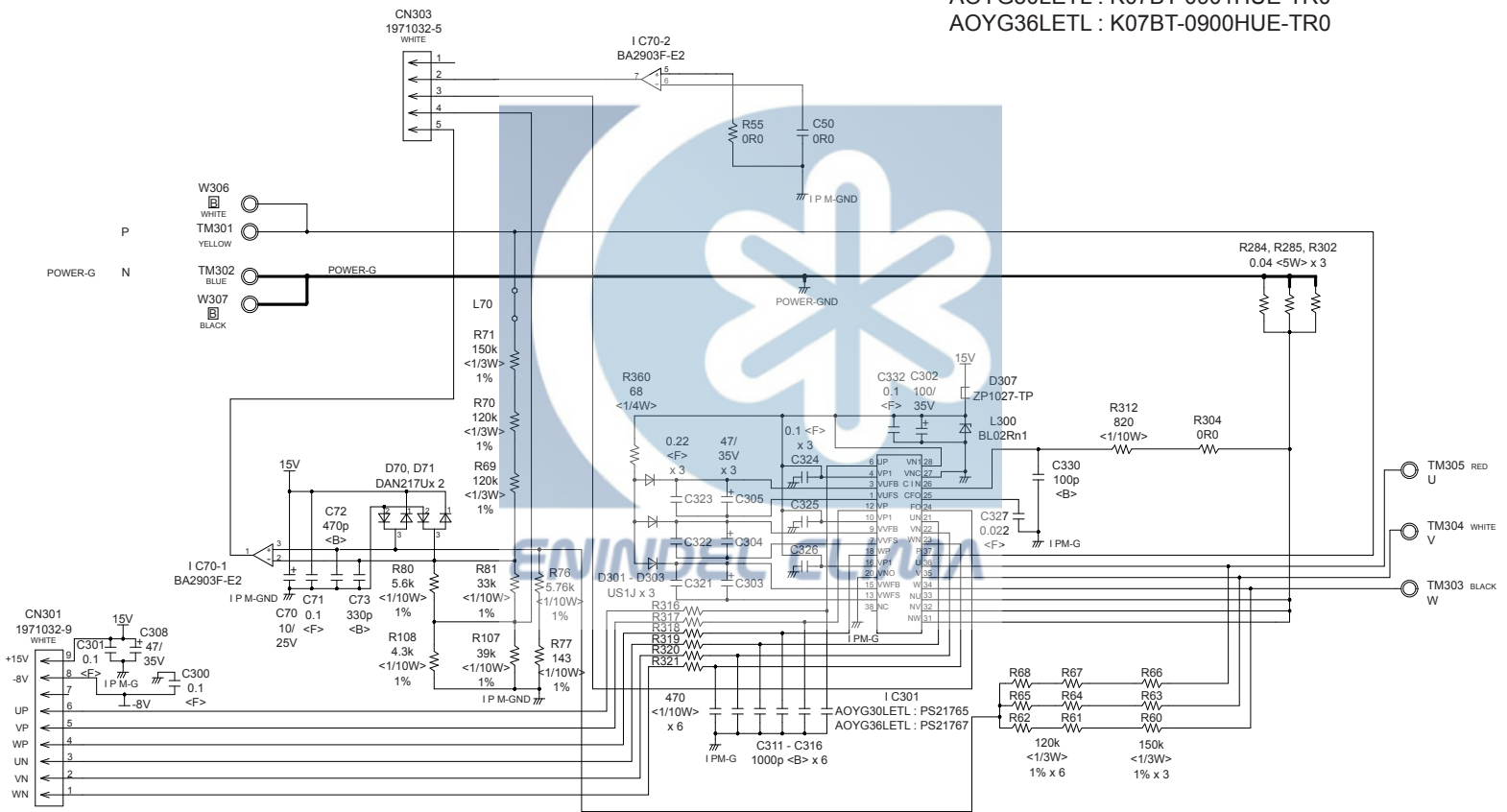

WWW.ENINDEL.COM

OUTDOOR UNIT
AOYG30LETL
FILTER PCB
K05CW-0901HUE-FLO

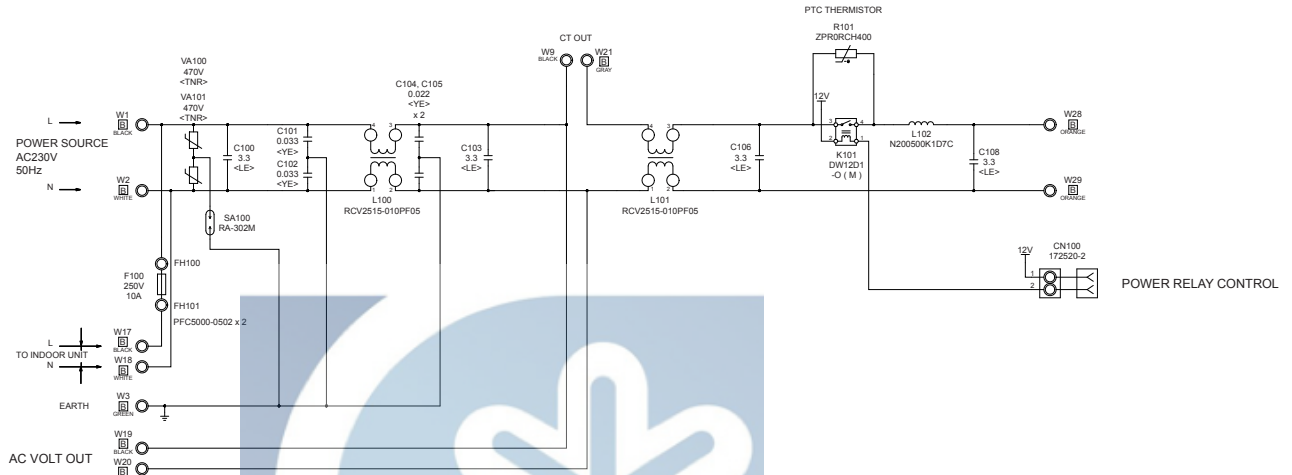

AOYG36LETL
FILTER PCB
K05CW-0900HUE-FLO

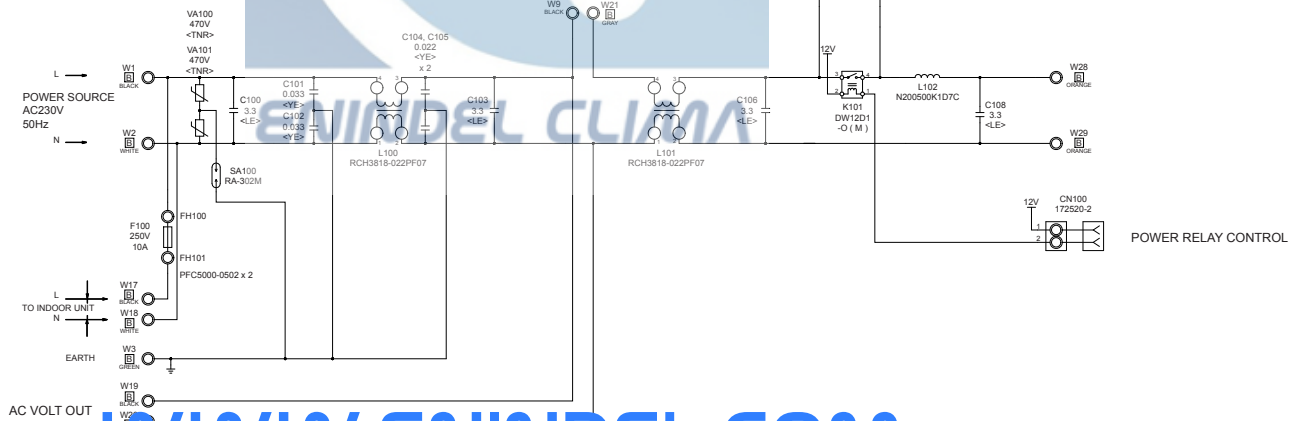

WWW.ENINDEL.COM

OUTDOOR UNIT
 AOYG30LETL
 CAPACITOR PCB
 K05FB-0901HUE-P0

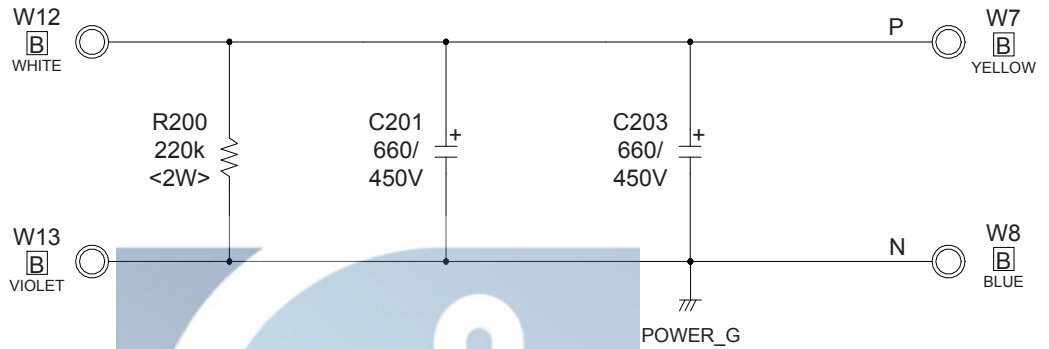

AOYG36LETL
 CAPACITOR PCB
 K05FB-0900HUE-P0

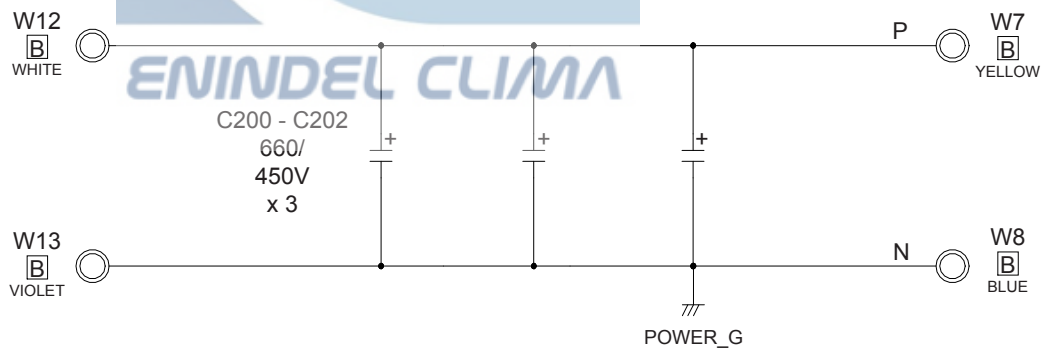

WWW.ENINDEL.COM

ERROR DETECTION

INDOOR UNIT and WIRED REMOTE CONTROL

If you use a wireless remote control, the lamp on the photo detector unit will output error codes by way of blinking patterns.
If you use a wired type remote control, error codes will appear on the remote control display. See the lamp blinking patterns and error codes in the table. An error display is displayed only during running.

Indoor unit display

Troubleshooting at the display is possible either on the wired or wireless remote control.

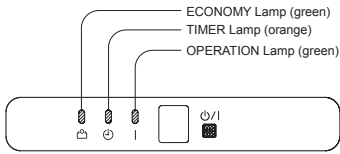

Remote control

This is possible only on a wired remote control. If an error occurs, the following display will be shown. ("Er" will appear in the set room temperature display.)

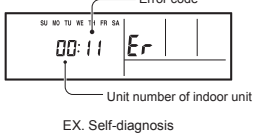

- : 0.5s on / 0.5s off
- ◇ : 0.1s on / 0.1s off
- () : Number of flashing

Indoor unit			Wired remote control	Description
OPERATION lamp (green)	TIMER lamp (orange)	ECONOMY lamp (green)		
●(1)	●(1)	◇	11	Serial communication error
●(1)	●(2)	◇	12	Wired remote control communication error
●(1)	●(5)	◇	15	Check run unfinished
●(2)	●(1)	◇	21	R.C. address or Refrigerant circuit address setting error [Simultaneous Multi]
●(2)	●(2)	◇	22	Indoor unit capacity error
●(2)	●(3)	◇	23	Combination error
●(2)	●(4)	◇	24	• Connection R.C. address error (indoor secondary unit) [Simultaneous Multi] • Connection R.C. address error (indoor unit or branch unit) [Flexible Multi]
●(2)	●(7)	◇	27	Primary unit, secondary unit set-up error [Simultaneous Multi]
●(3)	●(1)	◇	31	Power supply interruption error
●(3)	●(2)	◇	32	Indoor unit PCB model information error
●(3)	●(5)	◇	35	Manual auto switch error
●(4)	●(1)	◇	41	Room temp. sensor error
●(4)	●(2)	◇	42	Indoor unit Heat Ex. Middle temp. sensor error
●(5)	●(1)	◇	51	Indoor unit fan motor error
●(5)	●(3)	◇	53	Drain pump error
●(5)	●(7)	◇	57	Damper error
●(5)	●(15)	◇	5U	Indoor unit error
●(6)	●(2)	◇	62	Outdoor unit main PCB model information error or communication error
●(6)	●(3)	◇	63	Inverter error
●(6)	●(4)	◇	64	Active filter error, PFC circuit error
●(6)	●(5)	◇	65	Trip terminal L error
●(6)	●(10)	◇	6A	Display PCB microcomputers communication error

Indoor unit			Wired remote control	Description
OPERATION lamp (green)	TIMER lamp (orange)	ECONOMY lamp (green)		
●(7)	●(1)	◇	71	Discharge temp. sensor error
●(7)	●(2)	◇	72	Compressor temp. sensor error
●(7)	●(3)	◇	73	Outdoor unit Heat Ex. liquid temp. sensor error
●(7)	●(4)	◇	74	Outdoor temp. sensor error
●(7)	●(5)	◇	75	Suction Gas temp. sensor error
●(7)	●(6)	◇	76	• 2-way valve temp. sensor error • 3-way valve temp. sensor error
●(7)	●(7)	◇	77	Heat sink temp. sensor error
●(8)	●(2)	◇	82	• Sub-cool Heat Ex. gas inlet temp. sensor error • Sub-cool Heat Ex. gas outlet temp. sensor error
●(8)	●(3)	◇	83	Liquid pipe temp. sensor error
●(8)	●(4)	◇	84	Current sensor error
●(8)	●(6)	◇	86	• Discharge pressure sensor error • Suction pressure sensor error • High pressure switch error
●(9)	●(4)	◇	94	Trip detection
●(9)	●(5)	◇	95	Compressor rotor position detection error (permanent stop)
●(9)	●(7)	◇	97	Outdoor unit fan motor 1 error
●(9)	●(8)	◇	98	Outdoor unit fan motor 2 error
●(9)	●(9)	◇	99	4-way valve error
●(9)	●(10)	◇	9A	Coil (expansion valve) error
●(10)	●(1)	◇	A1	Discharge temp. error
●(10)	●(3)	◇	A3	Compressor temp. error
●(10)	●(4)	◇	A4	High pressure error
●(10)	●(5)	◇	A5	Low pressure error
●(13)	●(2)	◇	J2	Branch boxes error [Flexible Multi]

WWW.ENINDEL.COM

OUTDOOR UNIT

SPECIAL INSTALLATION SETTING

PUMP DOWN (Refrigerant collecting operation)

Perform the following procedures to collect the refrigerant when moving the indoor unit or the outdoor unit.

- (1) Press the push-button switch on the circuit board once.
The LED on the circuit board starts flashing (one second ON/one second OFF).
This indicates the start of PUMP DOWN operation.
When the switch is pressed while the compressor is in operation, PUMP DOWN operation starts automatically.
When the switch is pressed while the compressor is in stop, the compressor starts to operate automatically, and then move on to PUMP DOWN operation.
- (2) PUMP DOWN operation continues for about 1 minute.
When PUMP DOWN operation is completed, the compressor stops automatically.
Then close the 2-way valve and 3-way valve immediately.
- (3) Turn the power off.

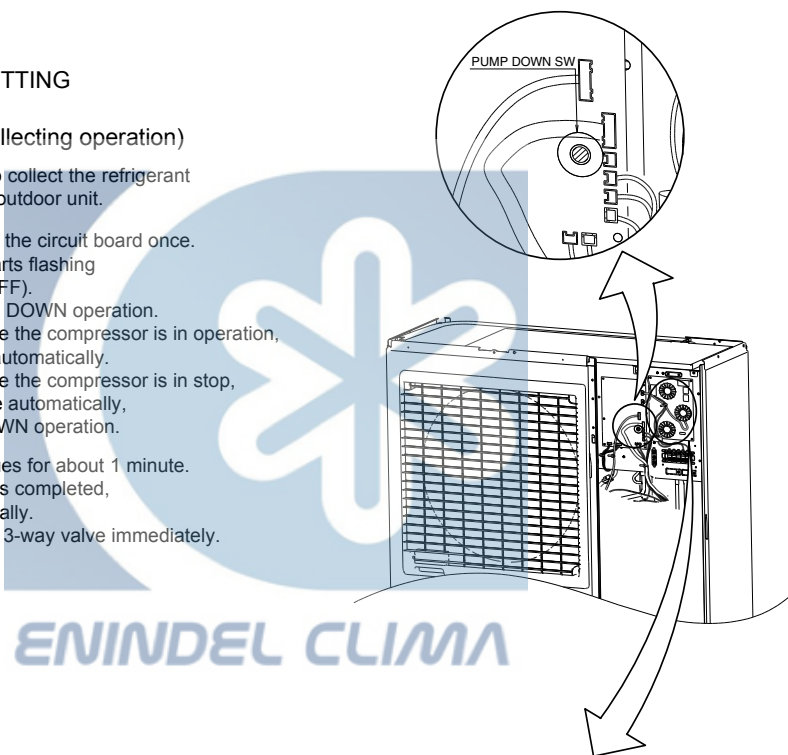

⚠ DANGER

This part (Choke coil) generates high voltages.
Never touch this part.

PARTS

INDOOR UNIT

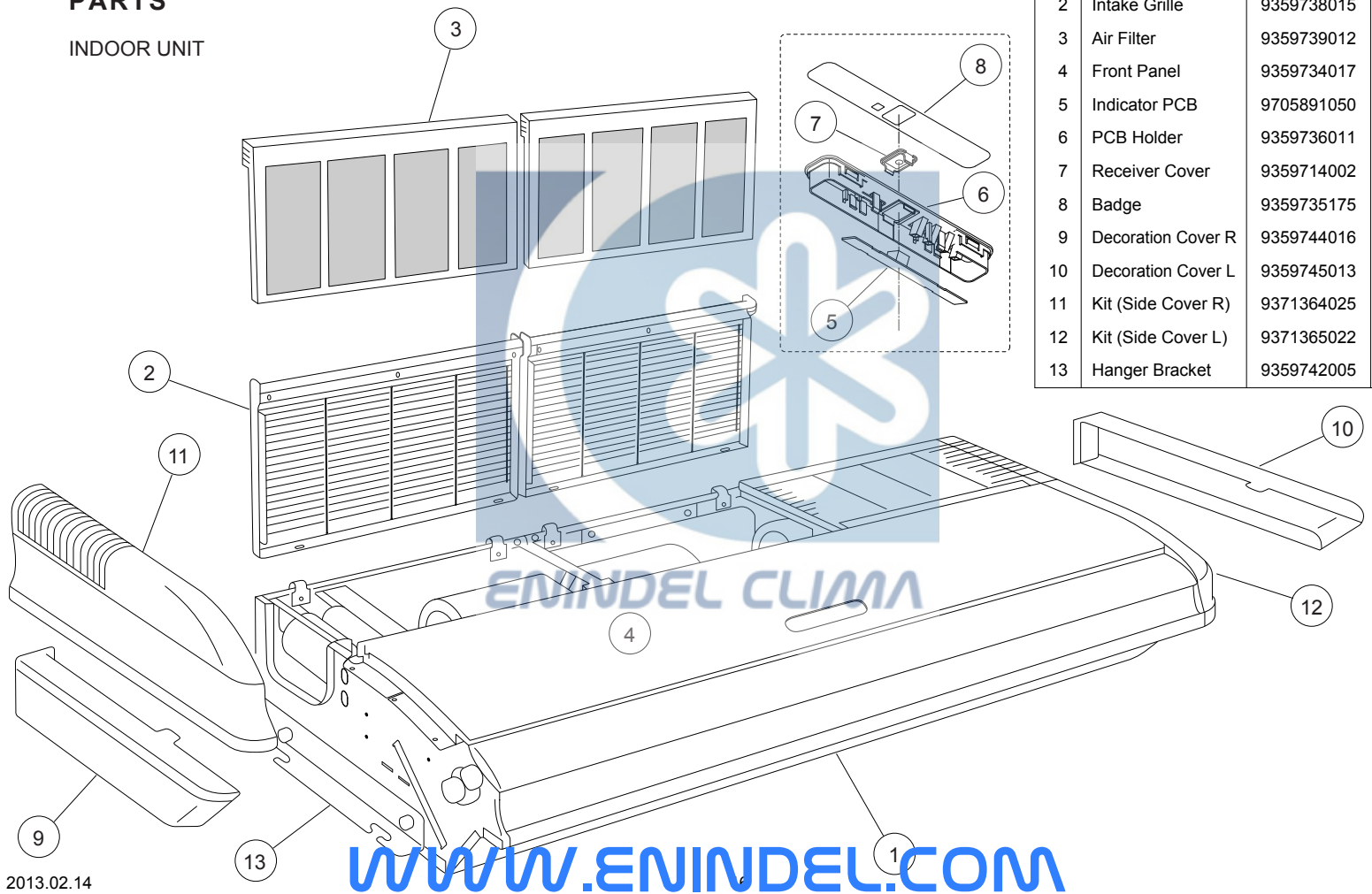

Ref.	Description	Part number
1	Top Cover	9359737018
2	Intake Grille	9359738015
3	Air Filter	9359739012
4	Front Panel	9359734017
5	Indicator PCB	9705891050
6	PCB Holder	9359736011
7	Receiver Cover	9359714002
8	Badge	9359735175
9	Decoration Cover R	9359744016
10	Decoration Cover L	9359745013
11	Kit (Side Cover R)	9371364025
12	Kit (Side Cover L)	9371365022
13	Hanger Bracket	9359742005

WWW.ENINDEL.COM

INDOOR UNIT
Fan motor

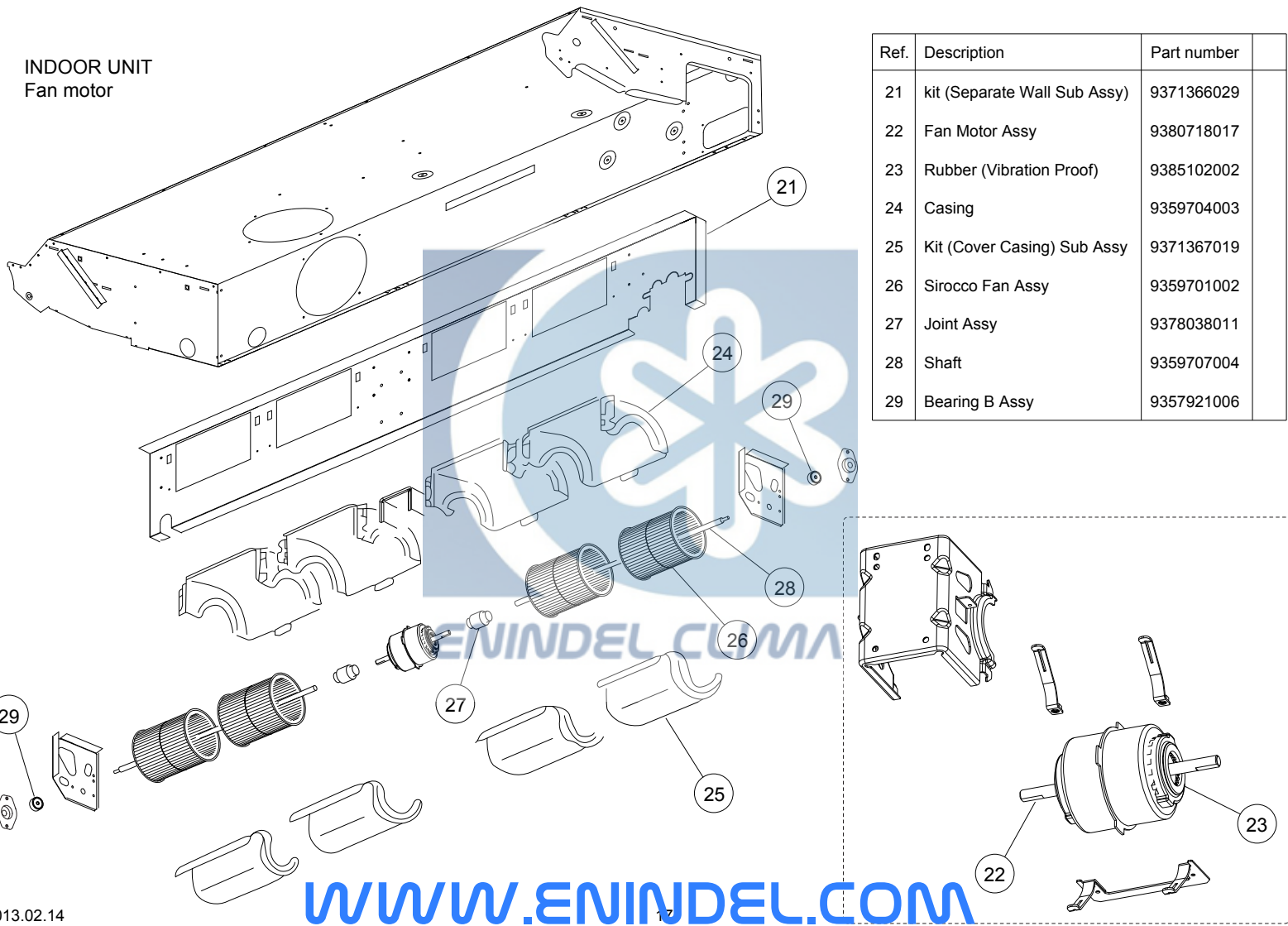

Ref.	Description	Part number
21	kit (Separate Wall Sub Assy)	9371366029
22	Fan Motor Assy	9380718017
23	Rubber (Vibration Proof)	9385102002
24	Casing	9359704003
25	Kit (Cover Casing) Sub Assy	9371367019
26	Sirocco Fan Assy	9359701002
27	Joint Assy	9378038011
28	Shaft	9359707004
29	Bearing B Assy	9357921006

2013.02.14

WWW.ENINDEL.COM

INDOOR UNIT
Evaporator
Drain pan
Flap

Ref.	Description	Part number
31	Kit (Base Sub Assy)	9371360010
32	Panel Left Sub Assy	9360427014
33	Kit (Panel Right Assy)	9371361017
34	Evaporator Sub Assy	9360428264
35	Kit (Pipe Cover L)	9371362014
36	kit (Pipe Cover R)	9371363011
37	Drain Pan Sub Assy	9360429032
38	Flap Assy	9359731016
39	Flap Spring	9359730002
40	Sector Gear	9359729006
41	Pinion Gear	9359728009
42	Motor Base	9359727002
43	Step Motor	9900362010
--	Drain Cap	9358746004
--	Pipe Thermistor	9900022020

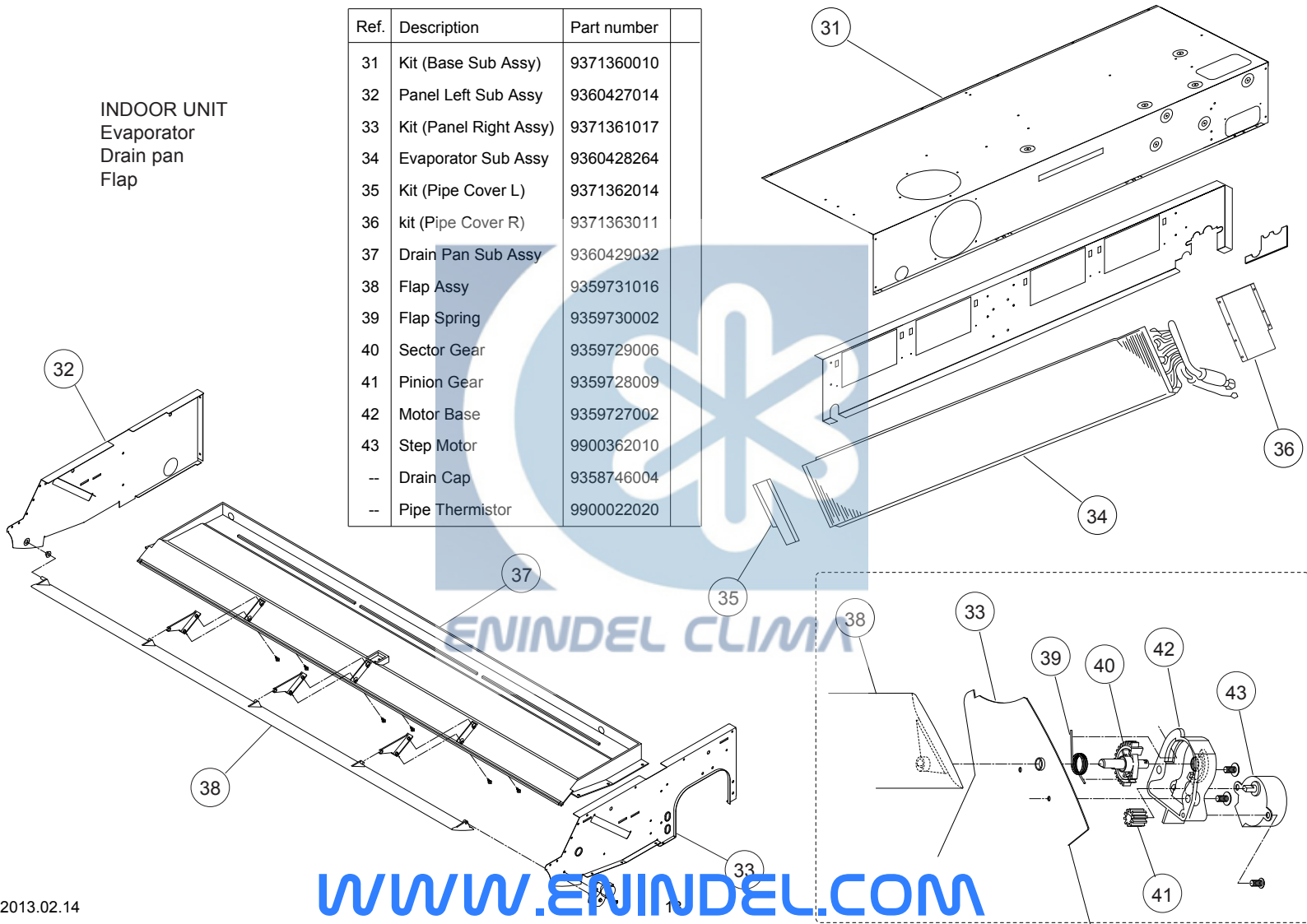

WWW.ENINDEL.COM

INDOOR UNIT
Louver Base Sub Assy

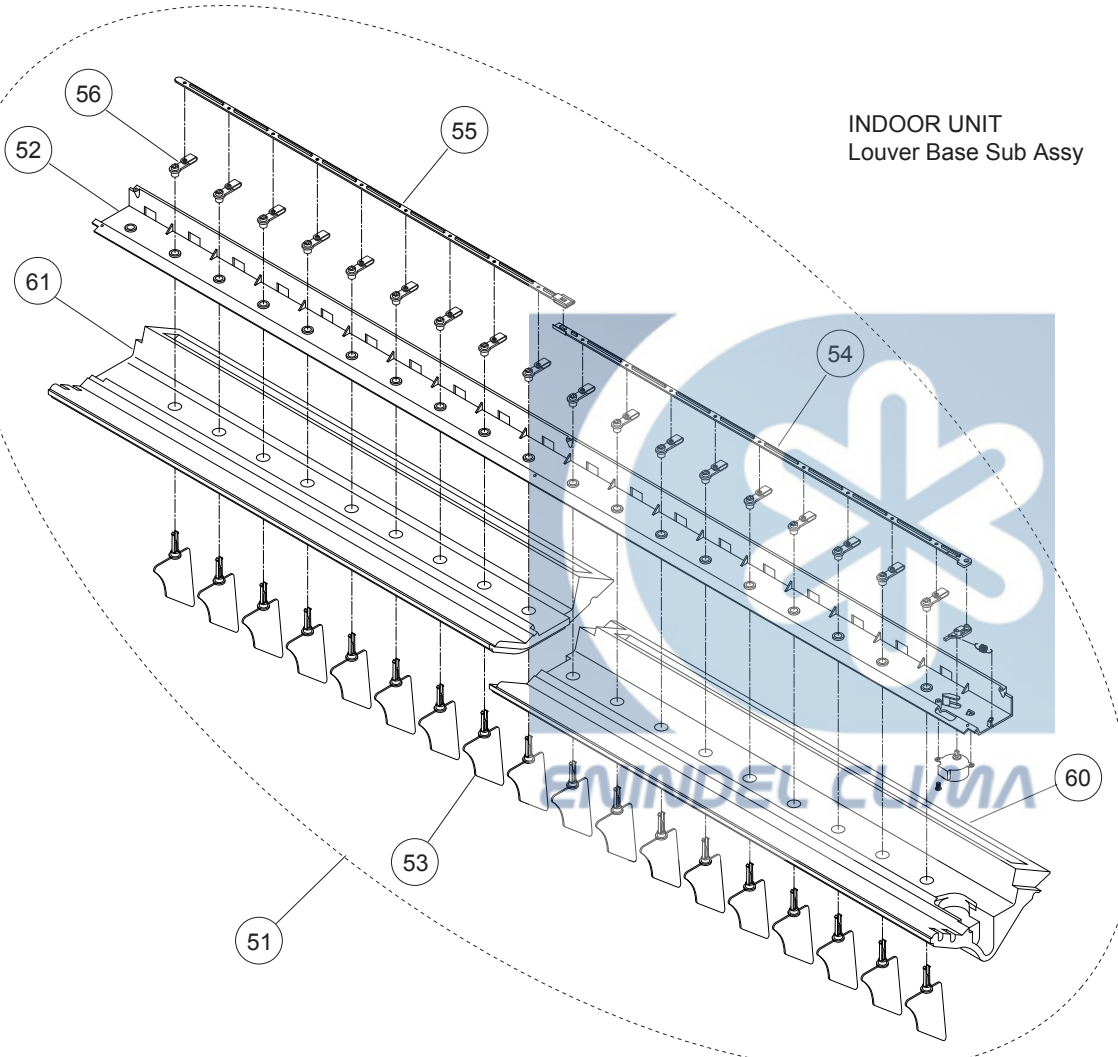

Ref.	Description	Part number
51	Louver Base Sub Assy	9360432049
52	kit (Louver Base)	9371369013
53	Louver	9359719014
54	Motor Rod	9359723004
55	Louver Rod	9359725008
56	Louver Stopper	9359724001
57	Louver Link	9359726005
58	Louver Spring	9359720003
59	Step Motor H	9900297015
60	Louver Insulation R	9359721000
61	Louver Insulation L	9359722007

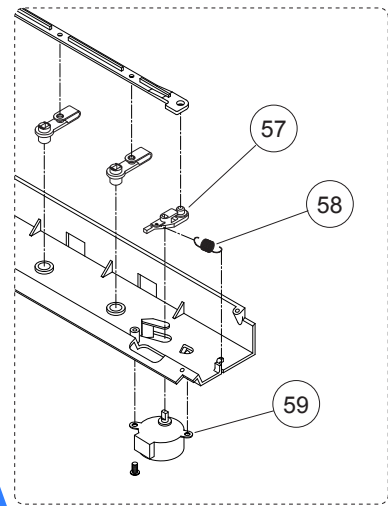

WWW.ENINDEL.COM

INDOOR UNIT
Control unit

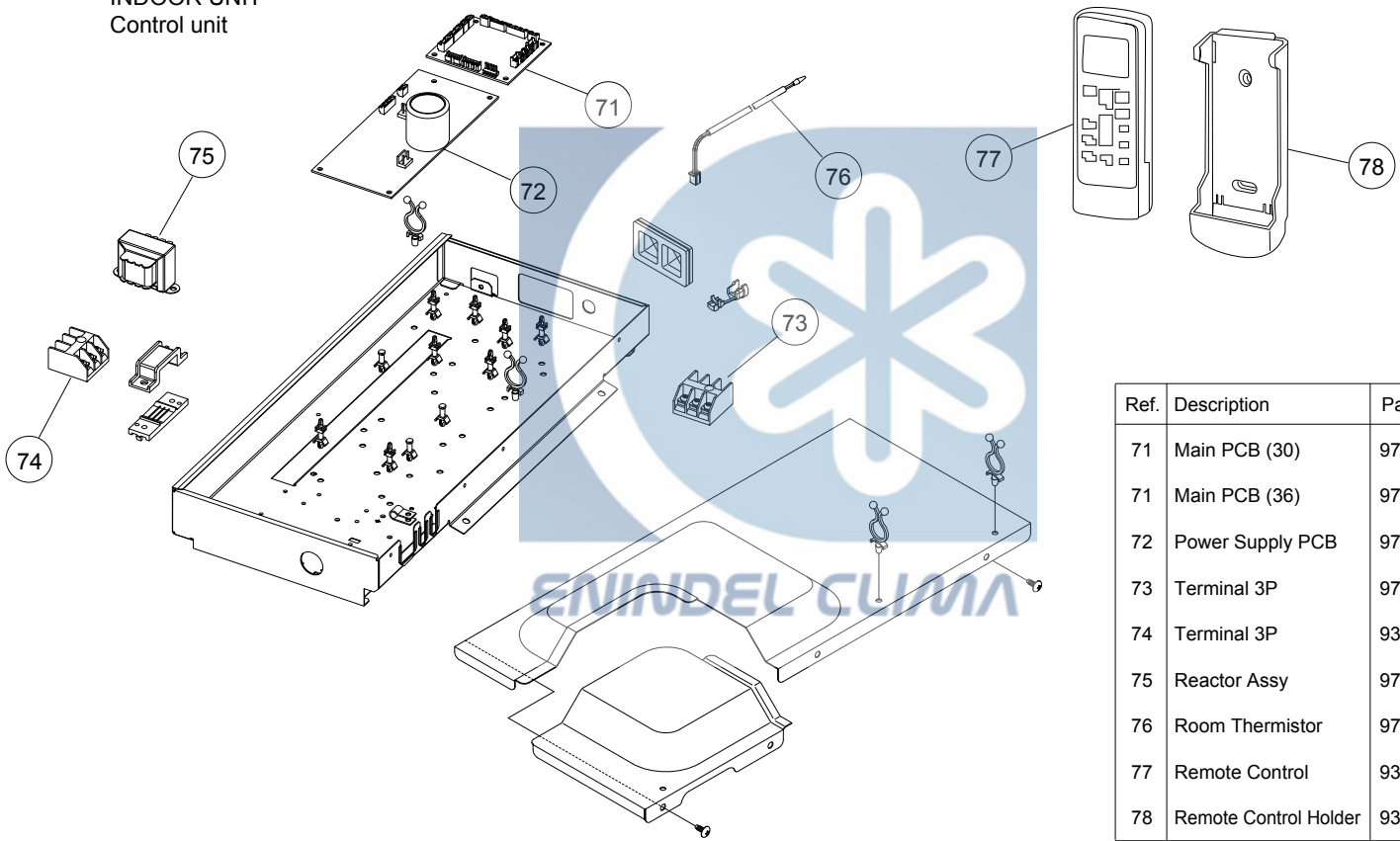

Ref.	Description	Part number
71	Main PCB (30)	9709245255
71	Main PCB (36)	9709245262
72	Power Supply PCB	9707398342
73	Terminal 3P	9703345012
74	Terminal 3P	9306489045
75	Reactor Assy	9707457018
76	Room Thermistor	9703299025
77	Remote Control	9379219037
78	Remote Control Holder	9305642045

WWW.ENINDEL.COM

PARTS

OUTDOOR UNIT

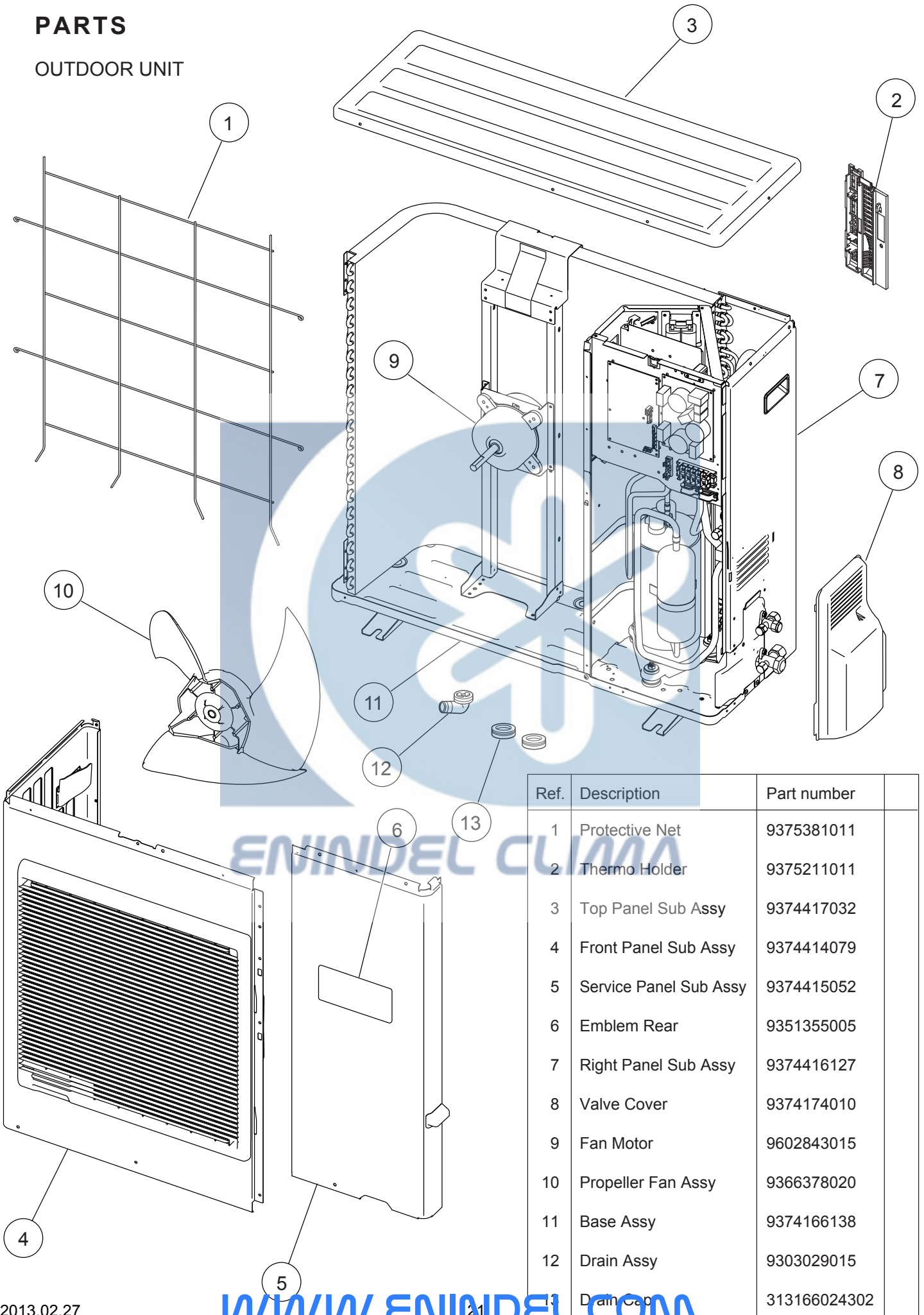

Ref.	Description	Part number
1	Protective Net	9375381011
2	Thermo Holder	9375211011
3	Top Panel Sub Assy	9374417032
4	Front Panel Sub Assy	9374414079
5	Service Panel Sub Assy	9374415052
6	Emblem Rear	9351355005
7	Right Panel Sub Assy	9374416127
8	Valve Cover	9374174010
9	Fan Motor	9602843015
10	Propeller Fan Assy	9366378020
11	Base Assy	9374166138
12	Drain Assy	9303029015
13	Drain Cap	313166024302

OUTDOOR UNIT

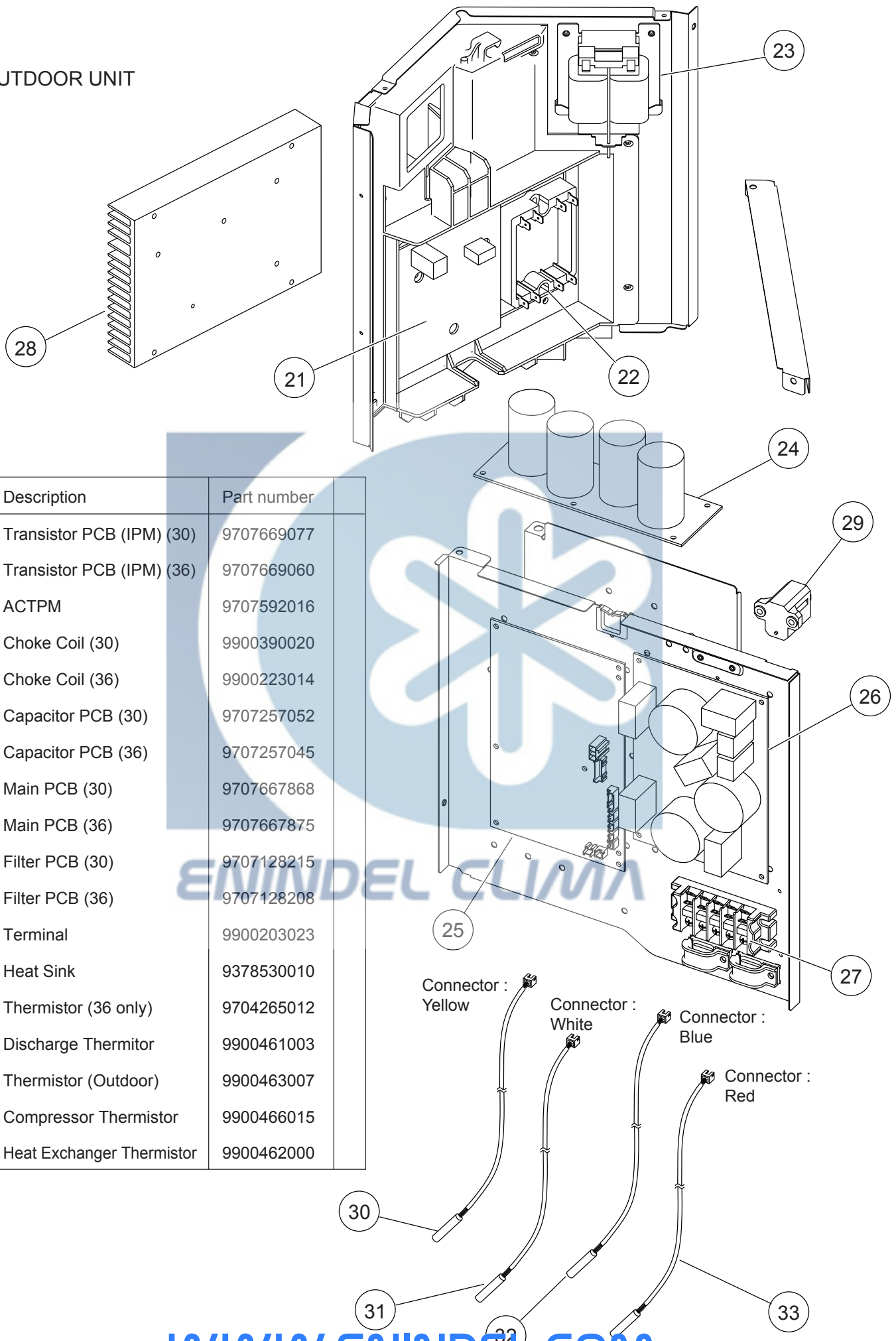

Ref.	Description	Part number
21	Transistor PCB (IPM) (30)	9707669077
21	Transistor PCB (IPM) (36)	9707669060
22	ACTPM	9707592016
23	Choke Coil (30)	9900390020
23	Choke Coil (36)	9900223014
24	Capacitor PCB (30)	9707257052
24	Capacitor PCB (36)	9707257045
25	Main PCB (30)	9707667868
25	Main PCB (36)	9707667875
26	Filter PCB (30)	9707128215
26	Filter PCB (36)	9707128208
27	Terminal	9900203023
28	Heat Sink	9378530010
29	Thermistor (36 only)	9704265012
30	Discharge Thermistor	9900461003
31	Thermistor (Outdoor)	9900463007
32	Compressor Thermistor	9900466015
33	Heat Exchanger Thermistor	9900462000

Connector : Yellow
 Connector : White
 Connector : Blue
 Connector : Red

OUTDOOR UNIT

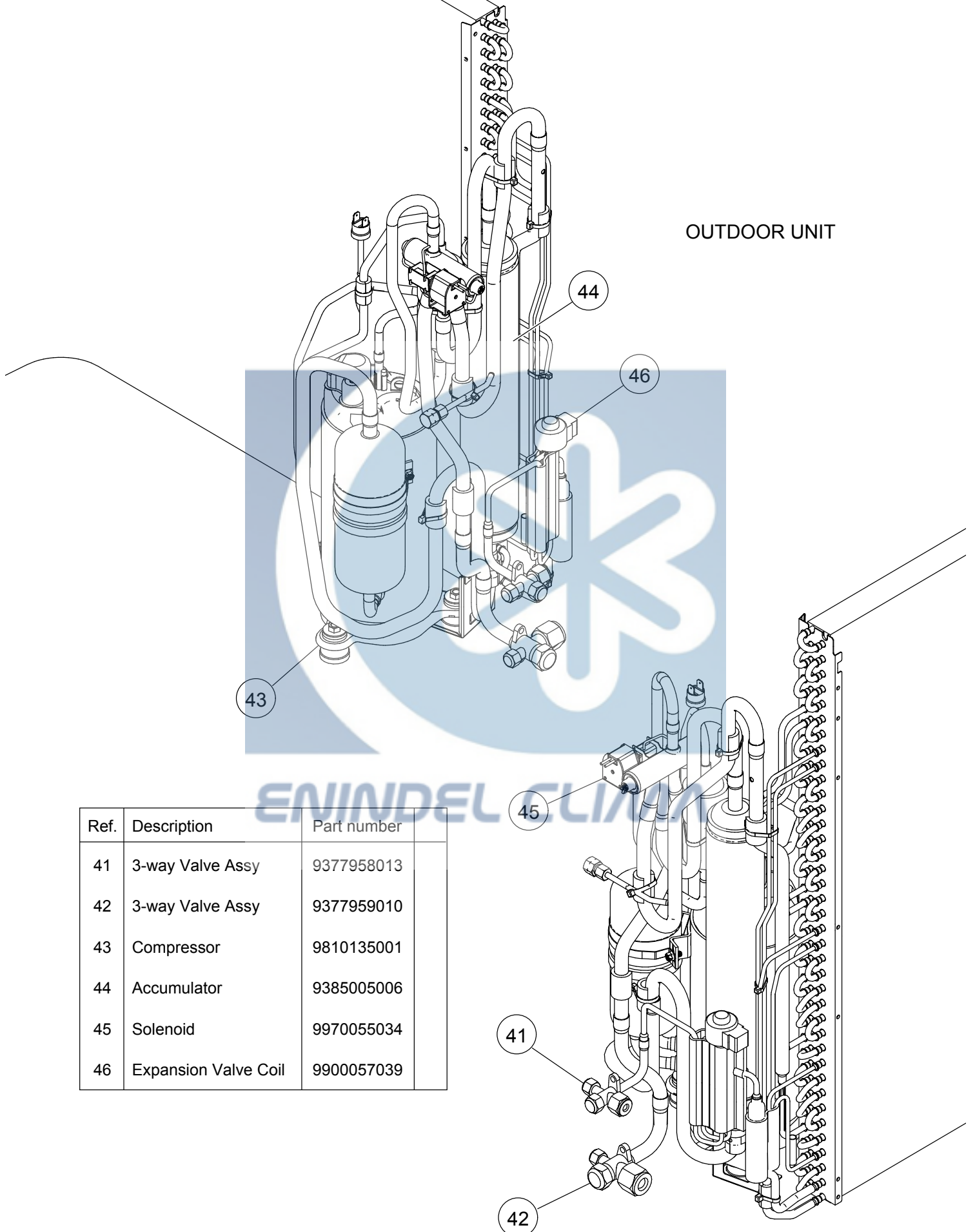



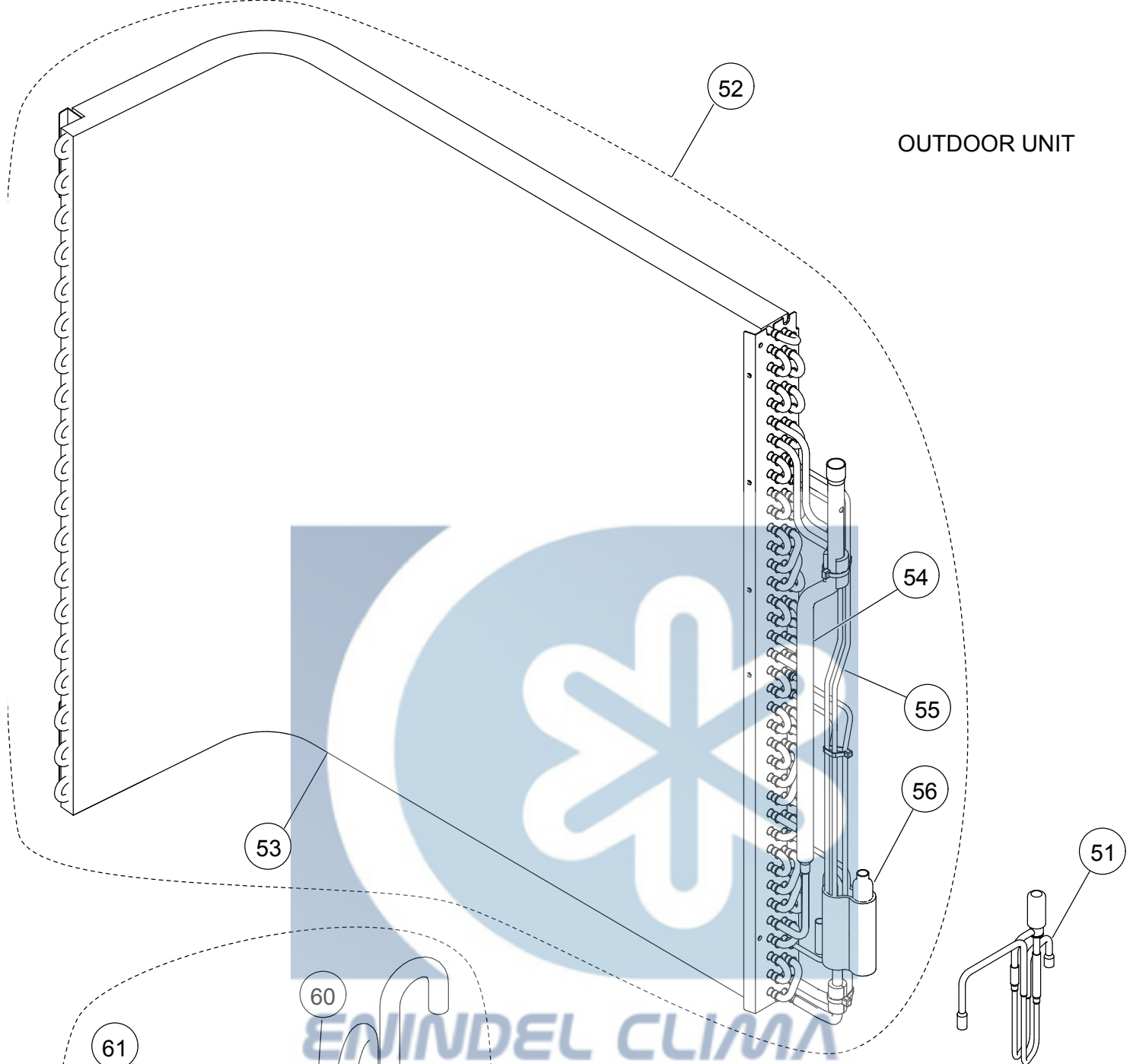





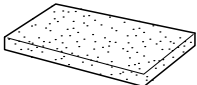

Ref.	Description	Part number
41	3-way Valve Assy	9377958013
42	3-way Valve Assy	9377959010
43	Compressor	9810135001
44	Accumulator	9385005006
45	Solenoid	9970055034
46	Expansion Valve Coil	9900057039

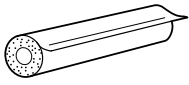

Ref.	Description	Part number
51	Expansion Valve Assy	9370947144
52	Condenser A Sub Assy	9374420308
53	Condenser A Assy	9374433056
54	Inlet Pipe (Cond) A Assy	9373461067
55	Outlet Pipe (Cond) A Assy	9374266104
56	Strainer Assy	9372524015
57	4-way Valve Assy	9374425198
58	4-way Valve	9900164010
59	Check Joint Assy	9372802038
60	Muffler	9372369050
61	Pressure Switch	9900186012

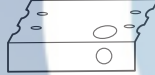
ACCESSORIES



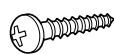

INDOOR UNIT

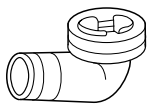
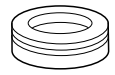
Name and Shape	Q'ty	Application	Part number
Drain hose insulation 	1	Adhesive type 70 x 230	9360464002
VT wire 	1	For fixing the drain hose L 280 mm	313806350303
Coupler heat insulator (large) 	2	For indoor side pipe joint (gas pipe)	9378173569
Coupler heat insulator (small) 	1	For indoor side pipe joint (liquid pipe)	9378173521
Cable tie 	Large 4	For fixing the coupler heat insulator	9301501001
	Small 4		312300787605
Special nut A (large flange) 	4	For installing indoor unit	313005446653
Special nut B (small flange) 	4	For installing indoor unit	313005446759
Installation template 	1	For positioning the indoor unit	9360022004
Auxiliary pipe assembly 	1	For connecting the piping	9374714025
Remote control 	1	For air conditioner operation	9379219037
Remote control holder 	1	For installing remote control on the wall	9305642045
Battery 	2	For remote control	0600185541
Tapping screw 	2	For mounting the remote control holder	0700019036

OUTDOOR UNIT

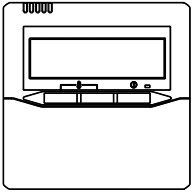
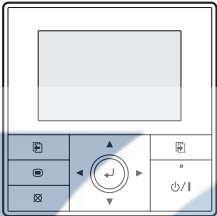
Name and Shape	Q'ty	Application	Part number
Drain pipe 	1	For drain piping work	9303029015
Drain cap 	2	For drain piping work	313166024302

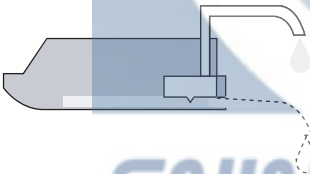
OPTIONAL PARTS

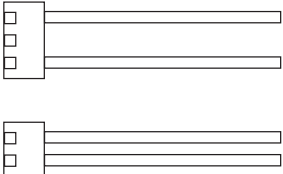
Name and Shape	Model name	Use
Wired remote control 	UTY-RNNYM	Unit control is performed by wired remote control
High functional wired remote control 	UTY-RVNYM	
Simple remote control 	UTY-RSNYM	For air conditioner operation
Drain pump unit 	UTR-DPB24T	
Round flange 	UTD-RF204	To take fresh air
External connect kit 	UTY-XWZX	For control input/output port



1302G4171

WWW.ENINDEL.COM