

Взрыв-схема
Овощерезка FNT

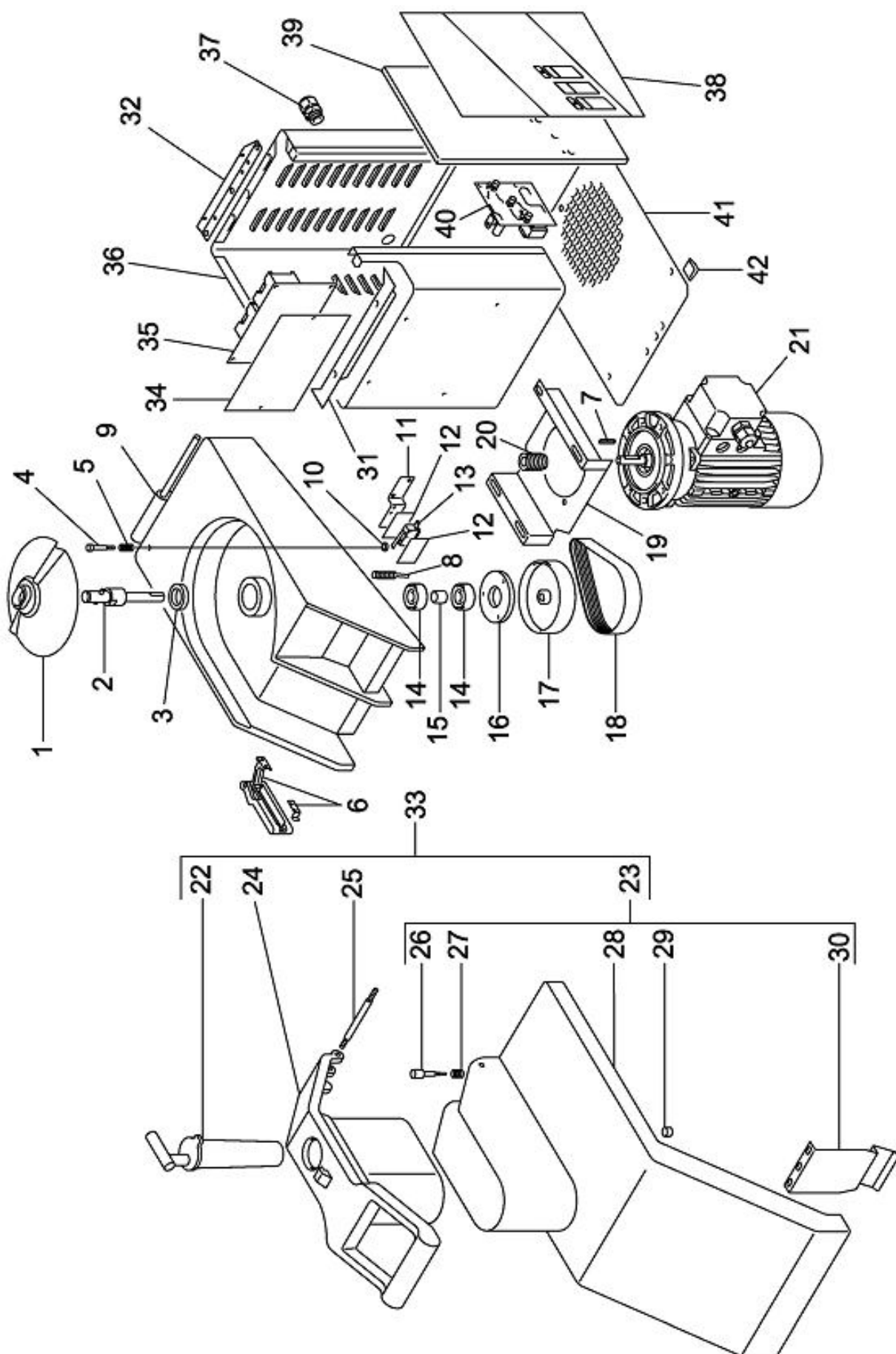

Pos. Ref.	Codice Code		Caratteristiche Features	Descrizione Description	Prezzo netto Net price	
1	36G6960	●		Disco espulsore	Ejector disk	6,50
2	36G6970			Albero	Shaft	25,00
3	3151280		ø28xø40x7	Paraolio	Oil seal	4,00
4	3190920			Perno	Pivot	2,00
5	36G7060			Molla	Spring	1,00
6	SL1528	●		Maniglia	Handle	20,00
7	SL0010		5x5x20	Linguetta	Key	0,50
8	32W3240	●		Microinterruttore	Microswitch	10,00
9	3600930			Bocca	Casing	38,00
10	3151690		ø5xø9x2	Parapolvere	Dust cover	3,50
11	35V4030			Staffa	Bracket	3,00
12	37R0050			Membrana	Vibrating diaphragm	1,00
13	32W2640	●		Microinterruttore	Microswitch	6,50
14	36F0090		6302 2RS	Cuscinetto	Bearing	6,00
15	35V3000			Distanziale	Spacer	2,00
16	3600940			Rosetta	Washer	5,00
17	36G6600			Puleggia	Pulley	9,00
18	36G6610	●	Poly V-559 j12	Cinghia	Belt	11,00
19	35V2970			Staffa	Bracket	9,00
20	36G0030			Puleggia	Pulley	6,00
21	SL1471		400V/3Ph/50Hz	Motore	Motor	68,00
21	32M0330		01/01/01 f.p.(*) - 400V/3Ph/50Hz	Motore	Motor	75,00
21	SL1470		230V/1Ph/50Hz	Motore	Motor	78,00
21	32M0340		01/01/01 f.p.(*) - 230V/1Ph/50Hz	Motore	Motor	115,00
21	32M0080		400V/3Ph/50Hz (2 speed)	Motore	Motor	190,00
22	6000770		Assembly	Pestello	Pusher	10,00
23	6000690		Assembly	Coperchio	Cover	57,00
24	6000760		Assembly	Leva	Lever	21,00
25	SL2410			Perno	Pivot	5,50
25	3190900		15/07/01 f.p.(*)	Perno	Pivot	2,00
26	36D2621			Perno	Pivot	8,50
27	36G6980			Molla	Spring	1,50
28	SA3500		Assembly	Coperchio	Cover	58,00
29	3600160			Magnete	Magnet	0,80
30	35Q9391			Staffa	Bracket	10,00
31	35V5590			Staffa	Bracket	8,00
32	35V2920			Staffa	Bracket	5,00
33	SA3550		Assembly	Coperchio	Cover	82,00
34	SL2783			Piastra	Plate	7,50
35	SL2510			Scheda elettronica	Electronic card	30,00
35	SL2511		(2 speed)	Scheda elettronica	Electronic card	44,00
35	32Z4840		15/09/03 f.p.(*)	Teleruttore	Remote control switch	18,00
36	35W4460			Carcassa	Housing	35,00
36	35W4520		01/01/01 f.p.(*)	Carcassa	Housing	45,00
37	SL0893		PG13,5	Pressacavo	Cable clamp	1,50
38	SL3538			Etichetta	Label	9,00
38	SL3539		(2 speed)	Etichetta	Label	9,00
39	35Q9530			Copertura	Covering	18,00
39	35V4090		01/01/01 f.p.(*)	Copertura	Covering	12,00
39	35V4100		(2 speed)	Copertura	Covering	17,00
40	32Z6990			Scheda elettronica	Electronic card	45,00
40	32Z7000		(2 speed)	Scheda elettronica	Electronic card	55,00
41	35M8260			Fondo	Bottom	11,00
42	3178340	●		Piedino	Foot	1,00

(*): fuori produzione / out of production

●: ricambio consigliato / spare part suggested