



DRYING

SINGLE POCKET DRYERS ADVANCE SR-11/14 TP2

CHARACTERISTICS

TP2

- User friendly and totally programmable 7" TP2.
- USB Connection. Online platform free of charge for programming, telemetry, data analysis...thanks to the IoT.
- Videos on display (ads, instructions, etc).
- 37 languages.

OUTSTANDING FEATURES

- Reversing drum action as standard.
- Stainless steel drum as standard.
- Frequency inverter as standard.

EFFICIENCY

- MIXED FLOW - mixed axial-radial airflow.
- Big fluff filter.

VERSATILITY

- Make to order - customisation.
- WET CLEANING.
- OPL > Multivending - Standard OPL model easily trasformable to coin laundry uses.

CONNECTIVITY

- Standard IoT FagorKonnect.
- Management of laundries: OPL and COIN.
- Remote payment.

ERGONOMICS

- Drawer as fluff filter, made of stainless steel.
- Biggest door diameters.
- Opening sense of door adjustable on site.

MAINTENANCE

- Hinged panel: easy and ergonomic access.
- Technical menu: statistics for technicians and maintenance with external console (with console option).

OTHERS

- Grey skinplate outer casing, stainless steel look.
- SOFT TOUCH - new drum with stamped holes.
- COOL DOWN - anti-wrinkle at the end of the cycle.
- Heating options: electric, gas and steam.
- CE approved.

OPTIONS

- iDRY - Humidity sensor.
- Double doorglass.
- FK - Fire Extinguishing System.
- Opposite door opening.
- Tropicalized model.
- Dosing/spraying system.
- Back panel external air + filter.
- Fluff filter with grid 0,6mm (standard is 0,3mm).
- Fluff filter with grid 1,2mm (standard is 0,3mm).
- Stainless steel front and side panels.
- Front panel in stainless steel.
- Steam battery in stainless steel.
- Low pressure steam battery.
- Reduced power (12kw instead of 18kw) for SR-14.
- Maritime wooden packing.
- Ship voltage for electric models: 440V III 50/60 Hz No neutral.
- Other voltages available.



	UNIT.	SR-11 TP2	SR-14 TP2		
CAPACITY					
Capacity 1/18	Kg	11,7	15		
Capacity 1/20	Kg	10,5	13,5		
Hourly Output (electr. // gas)	Kg/h	20,3 // 28,6	34-30		
Evaporation capacity (electr. // gas)	l/h	9,3 // 14,5	15,40		
DRUM					
Ø Drum	mm	750	750		
Ø Door (load hole)	mm	574	574		
Door center height	mm	976	976		
Load hole bottom height	mm	689	689		
Drum length	mm	475	610		
Drum volume	l	210	270		
POWER					
Drum motor power	Kw	0,37	0,37		
Fan motor power	Kw	0,25	0,25		
Electric heating power	Kw	12	18		
Total electric power (elec.model)	Kw	12,67	18,67		
Gas heating power	Kw	20,51	20,51		
Instant propane gas consumption (G31)	Kg/h	1,76	1,76		
Instant natural gas consumption (G20)	m3/h	2,17	2,17		
Total electric power (gas model)	Kw	0,67	0,67		
Steam heating power	Kw	30	30		
Total electric power (steam model)	Kw	0,67	0,67		
CONNECTIONS		ELECTRICAL	STEAM / GAS	ELECTRICAL	STEAM / GAS
Tension 230V - I + N + T	N° x mm2 / A	3 x 25 / 63A	3 x 1,5 / 20A	-	3 x 1,5 / 20A
Tension 230V - III + T	N° x mm2 / A	4 x 10 / 40A	3 x 1,5 / 20A	4x16 / 63A	3 x 1,5 / 20A
Tension 400V - III + N + T	N° x mm2 / A	5 x 4 / 25A	3 x 1,5 / 20A	5x10 / 32A	3 x 1,5 / 20A
Ø Gas inlet	BSP	1/2"		1/2"	
DIMENSIONS / PACKING DIMENSIONS					
Net Width / Gross Width	mm	785 / 865		785 / 865	
Net Depth / Gross Depth	mm	855 / 940		989 / 1074	
Net Height / Gross Height	mm	1.694 / 1.840		1694 / 1840	
Net weight / Gross weight	Kg	172 / 180		180 / 190	
OTHERS					
Max airflow	m3/h	850		850	
Ø Fume exhaust	mm	200		200	
Sound level	dB	64		64	

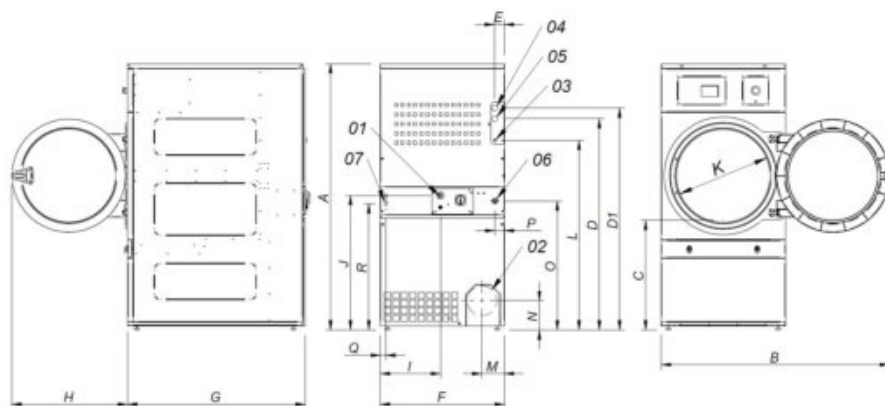

- 01 POWER SUPPLY
- 02 FUMES OUTLET Ø200
- 03 GAS INLET 1/2"
- 04 STEAM INLET 3/4"
- 05 CONDENSATE OUTLET 1/2"
- 06 SPRINKLER VALVE 3/4"
- 07 ETHERNET CONNECTION

	A	B	C	D	D1	E	E1	F	G	H	I	J	K	L	M	N	O	P
SR-11	1694*	1447	689	1354	1422	68	68	785	855	735	380	870	575	1226	133	180	35	805
SR-14	1694*	1447	689	1354	1422	68	68	785	989	735	380	870	575	1226	133	180	35	805

*Measurement with legs mounted (30mm)



DRYING

SINGLE POCKET DRYERS ADVANCE SR-18/22 TP2

CHARACTERISTICS

TP2

- User friendly and totally programmable 7" TP2.
- USB Connection. Online platform free of charge for programming, telemetry, data analysis...thanks to the IoT.
- Videos on display (ads, instructions, etc).
- 37 languages.

OUTSTANDING FEATURES

- Reversing drum action as standard.
- Stainless steel drum as standard.
- Frequency inverter as standard.

EFFICIENCY

- MIXED FLOW - mixed axial-radial airflow.
- Big fluff filter.

VERSATILITY

- Make to order - customisation.
- WET CLEANING.
- OPL > Multivending - Standard OPL model easily trasformable to coin laundry uses.

CONNECTIVITY

- Standard IoT FagorKonnect.
- Management of laundries: OPL and COIN
- Remote payment

ERGONOMICS

- Drawer as fluff filter, made of stainless steel.
- Biggest door diameters.
- Opening sense of door adjustable on site.

MAINTENANCE

- Hinged panel: easy and ergonomic access.
- Technical menu: statistics for technicians and maintenance with external console (with console option).

OTHERS

- Grey skinplate outer casing, stainless steel look.
- SOFT TOUCH - new drum with stamped holes.
- COOL DOWN - anti-wrinkle at the end of the cycle.
- Heating options: electric, gas and steam.
- CE approved.

OPTIONS

- iDRY - Humidity sensor.
- Double doorglass.
- FK - Fire Extinguishing System.
- Opposite door opening.
- Tropicalized model.
- Dosing/spraying system.
- Back panel external air + filter.
- Fluff filter with grid 0,6mm (standard is 0,3mm).
- Fluff filter with grid 1,2mm (standard is 0,3mm).
- Stainless steel front and side panels.
- Front panel in stainless steel.
- Steam battery in stainless steel.
- Low pressure steam battery.
- Reduced power (12kw instead of 18kw) for SR-18.
- Maritime wooden packing.
- Ship voltage for electric models: 440V III 50/60 Hz No neutral.
- Other voltages available.



UNIT.		SR-18 TP2	SR-22 TP2		
CAPACITY					
Capacity 1/18	Kg	18,3	24,3		
Capacity 1/20	Kg	16,5	21,9		
Hourly Output (electr. // gas)	Kg/h	28,3 // 31,9	34 // 40		
Evaporation capacity (electr. // gas)	l/h	14,1 // 16,3	17 // 20		
DRUM					
Ø Drum	mm	750	835		
Ø Door (load hole)	mm	574	574		
Door center height	mm	976	1.030		
Load hole bottom height	mm	689	743		
Drum length	mm	746	800		
Drum volume	l	330	438		
POWER					
Drum motor power	Kw	0,37	0,37		
Fan motor power	Kw	0,25	0,55		
Electric heating power	Kw	18	24		
Total electric power (elec.model)	Kw	18,67	24,97		
Gas heating power	Kw	20,51	31		
Instant propane gas consumption (G31)	kg/h	1,76	2,66		
Instant natural gas consumption (G20)	m3/h	2,17	3,28		
Total electric power (gas model)	Kw	0,67	0,97		
Steam heating power	Kw	30	49,2		
Total electric power (steam model)	Kw	0,67	0,97		
CONNECTIONS		ELECTRICAL	STEAM / GAS	ELECTRICAL	STEAM / GAS
Tension 230V - I + N + T	Nº x mm2 / A	-	3 x 1,5 / 20A	-	3 x 1,5 / 20A
Tension 230V - III + T	Nº x mm2 / A	4 x 16 / 63A	3 x 1,5 / 20A	4 x 25 / 80A	3 x 1,5 / 20A
Tension 400V - III + N + T	Nº x mm2 / A	5 x 10 / 32A	3 x 1,5 / 20A	5 x 10 / 40A	3 x 1,5 / 20A
Ø Gas inlet	BSP	1/2"		1/2"	
DIMENSIONS / PACKING DIMENSIONS					
Net Width / Gross Width	mm	785 / 865		890/970	
Net Depth / Gross Depth	mm	1.125 / 1.210		1.255/1.345	
Net Height / Gross Height	mm	1.694 / 1.840		1.812/1.940	
Net weight / Gross weight	Kg	187 / 200		210/230	
OTHERS					
Max airflow	m3/h	850		1.200	
Ø Fume exhaust	mm	200		200	
Sound level	dB	64		65	

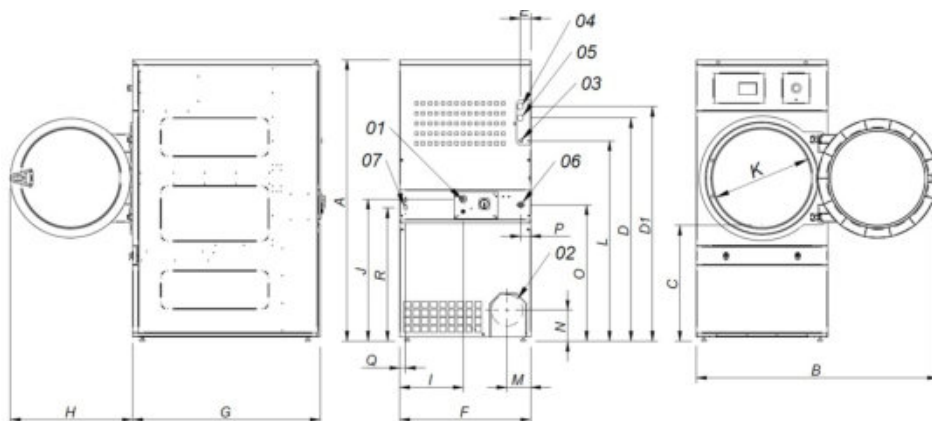

- 01 POWER SUPPLY
- 02 FUMES OUTPUT Ø200
- 03 GAS INLET 1/2"
- 04 STEAM INLET 3/4"
- 04 STEAM INLET 1" (SR-22)
- 05 CONDENSATE OUTLET 3/4"
- 05 CONDENSATE OUTLET 1" (SR-22)
- 06 SPRINKLER VALVE 3/4"
- 07 ETHERNET CONNECTION

	A	B	C	D	D1	E	E1	F	G	H	I	J	K	L	M	N	O	P
SR-18	1694*	1447	689	1354	1422	68	68	785	1125	735	380	870	575	1226	133	180	35	805
SR-22	1812*	1552	743	1430	1532	112	55	890	1255	735	107	920	575	1344	238	180	37	860

*Measurement with legs mounted (30mm)



DRYING

SINGLE POCKET DRYERS ADVANCE SR-28/35 TP2



CHARACTERISTICS

TP2

- User friendly and totally programmable 7" TP2.
- USB Connection. Online platform free of charge for programming, telemetry, data analysis...thanks to the IoT.
- Videos on display (ads, instructions, etc).
- 37 languages.

OUTSTANDING FEATURES

- Reversing drum action as standard.
- Stainless steel drum as standard.
- Frequency inverter as standard.

EFFICIENCY

- MIXED FLOW - mixed axial-radial airflow.
- Big fluff filter.

VERSATILITY

- Make to order - customisation.
- WET CLEANING.
- OPL > Multivending - Standard OPL model easily trasformable to coin laundry uses.

CONNECTIVITY

- Standard IoT FagorKconnect.
- Management of laundries: OPL and COIN.
- Remote payment.

ERGONOMICS

- Drawer as fluff filter, made of stainless steel.
- Biggest door diameters.
- Opening sense of door adjustable on site.

MAINTENANCE

- Hinged panel: easy and ergonomic access.
- Technical menu: statistics for technicians and maintenance with external console (with console option).

OTHERS

- Grey skinplate outer casing, stainless steel look.
- SOFT TOUCH - new drum with stamped holes.
- COOL DOWN - anti-wrinkle at the end of the cycle.
- Heating options: electric, gas and steam.
- CE approved.

OPTIONS

- iDRY - Humidity sensor.
- Double doorglass.
- FK - Fire Extinguishing System.
- Opposite door opening.
- Tropicalized model.
- Dosing/spraying system.
- Back panel external air + filter.
- Fluff filter with grid 0,6mm (standard is 0,3mm).
- Fluff filter with grid 1,2mm (standard is 0,3mm).
- Stainless steel front and side panels.
- Front panel in stainless steel.
- Steam battery in stainless steel.
- Low pressure steam battery.
- Maritime wooden packing.
- Ship voltage for electric models: 400V III 50/60 Hz No neutral.
- Other voltages available.

	UNIT.	SR-28 TP2	SR-35 TP2		
CAPACITY					
Capacity 1/18	Kg	30,5	36,6		
Capacity 1/20	Kg	27,5	33		
Hourly Output (electr. // gas)	Kg/h	48,4 // 59,3	60 // 63,9		
Evaporation capacity (electr. // gas)	l/h	26,1 // 30,9	31,1 // 32,1		
DRUM					
Ø Drum	mm	947	947		
Ø Door	mm	802	802		
Door center height	mm	1.040	1.040		
Load hole bottom height	mm	640	640		
Drum length	mm	780	936		
Drum volume	l	549	659		
POWER					
Drum motor power	Kw	0,55	0,55		
Fan motor power	Kw	0,55	0,55		
Electric heating power	Kw	30	36		
Total electric power (elec.model)	Kw	31,15	37,15		
Gas heating power	Kw	41	41		
Instant propane gas consumption (G31)	Kg/h	3,51	5,14		
Instant natural gas consumption (G20)	m3/h	4,34	6,35		
Total electric power (gas model)	Kw	1,15	1,15		
Steam heating power	Kw	50,1	50,1		
Total electric power (steam model)	Kw	1,15	1,15		
CONNECTIONS		ELECTRICAL	STEAM / GAS	ELECTRICAL	STEAM / GAS
Tension 230V - I + N + T	N° x mm2 / A	-	3 x 1,5 / 20A	-	3 x 1,5 / 20A
Tension 230V - III + T	N° x mm2 / A	4 x 35 / 100A	3 x 1,5 / 20A	4 x 50 / 125A	3 x 1,5 / 20A
Tension 400V - III + N + T	N° x mm2 / A	5 x 16 / 63A	3 x 1,5 / 20A	5 x 16 / 63A	3 x 1,5 / 20A
Ø Gas inlet	BSP	1/2"		1/2"	
DIMENSIONS / PACKING DIMENSIONS					
Net Width / Gross Width	mm	985/1.065		985/1.065	
Net Depth / Gross Depth	mm	1.054/1.154		1.210/1.310	
Net Height / Gross Height	mm	1.975/2.080		1.975/2.080	
Net weight / Gross weight	Kg	230/260		260/285	
OTHERS					
Max airflow	m3/h	1.200		1.200	
Ø Fume exhaust	mm	200		200	
Sound level	dB	65		65	

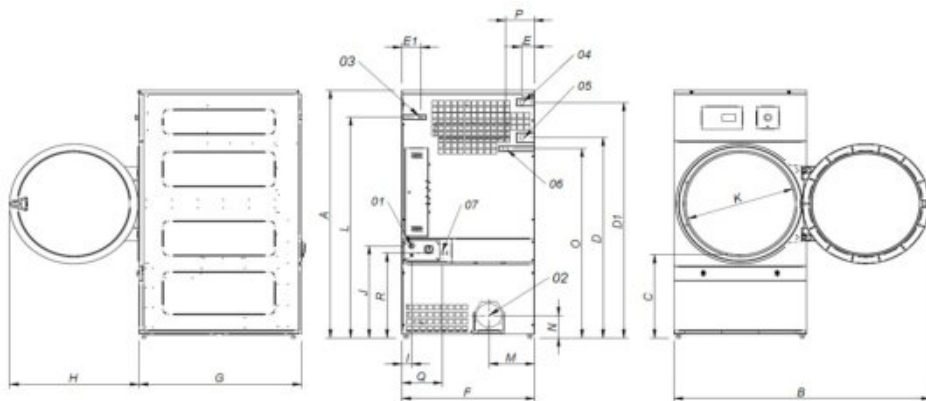

- 01 POWER SUPPLY
- 02 FUMES OUTPUT Ø200
- 03 GAS INLET 1/2"
- 04 STEAM INLET 1"
- 05 CONDENSATE OULET 1"
- 06 SPRINKLER VALVE 3/4"
- 07 ETHERNET CONNEXION

	A	B	C	D	D1	E	E1	F	G	H	I	J	K	L	M	N	O	P
SR-28	1975*	1910	660	1590	1875	102	130	985	1054	970	70	730	802	1760	337	178	301	676
SR-35	1975*	1910	660	1590	1875	102	130	985	1210	970	70	730	802	1760	337	178	301	676

*Measurement with legs mounted (30mm)



DRYING

SINGLE POCKET DRYERS ADVANCE SR-45/60/80 TP2

CHARACTERISTICS

TP2

- User friendly and totally programmable 7" TP2.
- USB Connection. Online platform free of charge for programming, telemetry, data analysis... thanks to the IoT.
- Videos on display (ads, instructions, etc).
- 37 languages.

OUTSTANDING FEATURES

- Reversing drum action as standard.
- Stainless steel drum as standard.
- Frequency inverter as standard.

EFFICIENCY

- MIXED FLOW - mixed axial-radial airflow.
- Big fluff filter.

VERSATILITY

- Make to order - customisation.
- WET CLEANING.

CONNECTIVITY

- Standard IoT FagorKconnect.

ERGONOMICS

- Drawer as fluff filter, made of stainless steel.
- Biggest door diameters.
- Opening sense of door adjustable on site.

MAINTENANCE

- Hinged panel: easy and ergonomic access.
- Technical menu: statistics for technicians and maintenance with external console (with console option).

OTHERS

- Steam battery in stainless steel (up to 15 bar pressure).
- Grey skinplate outer casing, stainless steel look.
- SOFT TOUCH - new drum with stamped holes.
- COOL DOWN - anti-wrinkle at the end of the cycle.
- Heating options: electric, gas and steam.
- CE approved.

OPTIONS

- **NEW** automatic or manual guillotine door.
- **NEW** tilling front kit.
- iDRY - Humidity sensor.
- Double doorglass.
- FK - Fire Extinguishing System.
- Opposite door opening.
- Tropicalized model.
- Dosing/spraying system.
- Back panel external air + filter.
- Fluff filter with grid 0,6mm (standard is 0,3mm).
- Fluff filter with grid 1,2mm (standard is 0,3mm).
- Stainless steel front and side panels.
- Front panel in stainless steel.
- Low pressure steam battery.
- Maritime wooden packing.
- Ship voltage for electric models: 440V III 50/60 Hz No neutral.
- Other voltages available.



	UNIT.	SR-45 TP2	SR-60 TP2	SR-80 TP2			
CAPACITY							
Capacity 1/18	Kg	49,8	66,8	83,3			
Capacity 1/20	Kg	44,8	60,1	75			
Hourly Output (electr. // gas)	Kg/h	80,4 // 84,4	120 // 128,6	128,6 // 173,1			
Evaporation capacity (electr. // gas)	l/h	40,2 // 45,5	60,2 // 65,8	64 // 86,5			
DRUM							
Ø Drum	mm	1.225	1.225	1.225			
Ø Door	mm	802	802	802			
Door center height	mm	1.275	1.275	1.275			
Load hole bottom height	mm	874	874	874			
Drum length	mm	760	1.020	1.252			
Drum volume	l	896	1.202	1.500			
POWER							
Drum motor power	Kw	0,75	1,1	1,5			
Fan motor power	Kw	1,1	1,1	1,1			
Electric heating power	Kw	54	72	72			
Total electric power (elec.model)	Kw	55,9	74,25	74,65			
Gas heating power	Kw	60	90	120			
Instant propane gas consumption (G31)	Kg/h	5,14	7,71	10,28			
Instant natural gas consumption (G20)	m3/h	6,35	9,53	12,71			
Total electric power (gas model)	Kw	1,9	2,25	2,65			
Steam heating power	Kw	91,3	128	128			
Total electric power (steam model)	Kw	1,9	2,25	2,65			
CONNECTIONS		ELECTRICAL	STEAM / GAS	ELECTRICAL	STEAM / GAS	ELECTRICAL	STEAM / GAS
Tension 230V - I + N + T	Nº x mm2 / A	-	-	-	-	-	-
Tension 230V - III + T	Nº x mm2 / A	-	4 x 2,5 / 20A	-	4 x 2,5 / 32A	-	4 x 2,5 / 32A
Tension 400V - III + N + T	Nº x mm2 / A	5 x 35 / 100A	5 x 1,5 / 20A	5 x 50 / 125A	5 x 1,5 / 32A	5 x 50 / 125A	5 x 1,5 / 32A
Ø Gas inlet	BSP	3/4"		3/4"		3/4"	
DIMENSIONS / PACKING DIMENSIONS							
Net Width / Gross Width	mm	1.270/1.330		1.270/1.330		1.270/1.330	
Net Depth / Gross Depth	mm	1.106/1.185		1.366/1.445		1.598/1.705	
Net Height / Gross Height	mm	2.380/2.150		2.380/2.150		2.380/2.150	
Height without heating battery	mm	1.950		1.950		1.950	
Net weight / Gross weight	Kg	395/430		529/575		657/715	
OTHERS							
Max airflow	m3/h	3.000		3.000		3.000	
Ø Fume exhaust	mm	300		300		300	
Sound level	dB	67		67		67	

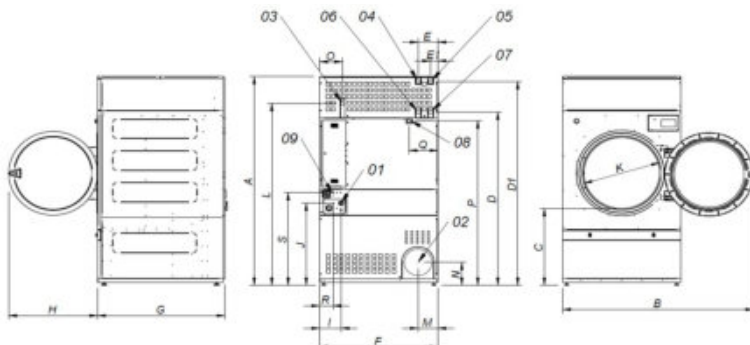

- 01 POWER SUPPLY
- 02 FUMES OUTPUT Ø300
- 03 GAS INLET 3/4"
- 04 STEAM INLET (SR-45) 1"
- 05 STEAM INLET (SR-60/80) 1"
- 06 CONDENSATE OUTLET (SR-45) 1"
- 07 CONDENSATE OUTLET (SR-60/80) 1"
- 08 SPRINKLER VALVE 3/4"
- 09 ETHERNET CONNECTION

	A	B	C	D	D1	E	E1	F	G	H	I	J	K	L	M	N	O	P	Q
SR-45	2380*	2045	874	1981	2311	211	80	1270	1106	956	248	935	802	2088	214	240	244	160	1053
SR-60	2380*	2045	874	1981	2311	211	80	1270	1366	956	248	935	802	2088	214	240	244	160	1053
SR-80	2380*	2045	874	1981	2311	211	80	1270	1598	956	248	935	802	2088	214	240	244	160	1053

*Measurement with legs mounted (30mm)